

## Resistivity and induced polarization to support morphological modeling in limestone mining

Antonio Carlos Martins, Vagner Elis, Giorgio de Tomi\*, Jorge Bettencourt and Tatiane Marin

Received: July 16, 2015; accepted: August 09, 2016; published on line: October 01, 2016

DOI: 10.19155/geofint.2016.055.4.1

### Resumen

Este artículo presenta los resultados de la aplicación de estudios geofísicos usados para la actualización del modelo morfológico de un depósito de caliza y gneis perteneciente a una compañía minera cerca de la ciudad de Taubaté, estado de Sao Paulo, Brasil. La investigación comenzó con un test de verificación de exactitud del método geofísico de estudio, el cual fue realizado con una campaña de perforación realizada previamente en la misma área de estudio, con el objetivo de confirmar la posibilidad de utilizar los métodos de Sondeo Eléctrico Vertical (SEV) y de Polarización Inducida (IP) para obtener la información requerida para el modelado del depósito morfológico. Como resultado, la aplicación de los métodos geofísicos en el área de estudio redujo el tiempo de recolección hasta un 75% y presentaron un nivel de precisión similar al de los métodos de exploración convencionales utilizados para los mismos objetivos del estudio.

Palabras clave: Geofísica, electro resistividad, polarización inducida, modelado morfológico, minería de caliza.

### Abstract

This paper presents the results of the application of geophysical surveys to update the morphological model of a limestone and gneiss deposit of a mining company near the city of Taubaté, Brazil. The research began with a test to verify the accuracy of the geophysical survey method and it was conducted in the same area as a previous drilling campaign with the aim of confirming the possibility of using Vertical Electrical Sounding (VES) and induced polarization (IP) methods, in order to obtain the required information for the deposit morphological modeling. As a result, the application of geophysical methods in the study area reduced up to 75% the data collection time and presented similar accuracy levels as conventional exploration methods used for the same research objectives.

Key words: Geophysics, electro-resistivity, induced polarization, morphological modeling, limestone mining.

---

A. C. Martins  
Department of Mining and Petroleum Engineering  
Universidade of São Paulo  
São Paulo, Brazil

V. Elis  
Professor Doctor II in the Geophysics Department at  
IAG/USP  
Universidade of São Paulo  
São Paulo, Brazil

G. de Tomi\*  
Professor of Mining Engineering and Director  
USP Center for Responsible Mining (NAP.Mineração)  
Universidade of São Paulo  
São Paulo, Brazil  
*\*Corresponding author: gdetomi@usp.br*

J. Bettencourt  
Emeritus Professor of the Geosciences Institute at the  
Universidade of São Paulo  
São Paulo, Brazil

T. Marin  
Department of Mining and Petroleum Engineering  
Universidade of São Paulo  
São Paulo, Brazil

## Introduction

Geophysical surveys were employed to update the morphological model of a mineral deposit owned by an aggregate mining company located near the city of Taubaté, Brazil. The company owns a mining title encompassing an area of 50 ha and it has recently applied for an extension of its mining title to an exploration permit for an area of 246 ha, as shown in Figure 1 (UTM SF-23). The deposit is a limestone orebody surrounded by gneiss. The company traditionally produces limestone and gneiss for aggregates. A new exploitation stage is planned for the extended exploration permit, which will be focused on the gneiss occurrence. For the planning of this new stage, it is important to know the thickness of the layer of soil above the gneiss bedrock.

The purpose of this paper is to describe the application of geophysics in order to streamline data collection for updating of the morphological model in the area of the new mining title of the company to meet the time limits specified by the company. Due to the low cost and the possibility of covering broad areas in a short time, geophysical methods are an important tool in mineral research (REM).

Ravindran (2010) conducted a geoelectric resistivity survey along a 14-km transect at the boundary between Kericho and Nakuru counties (India) to observe the structure beneath and its relation to groundwater occurrence. In this case, 2D electrical resistivity (ER) imaging has proved to be an excellent tool to delineate groundwater potential zones and subsurface lithology. According to Frasheri *et al.* (1995), the most important geophysical methods used for this purpose are electrical prospecting, gravity, magnetics, and electromagnetics.

The conventional method that is usually used by the company for this type of data collection is based on rotary drilling holes with core recovery. However, due to the deadlines set by the company, an exploration campaign using the conventional procedures would take about 60 days to complete using between three and four drilling equipment units.

To reduce the time taken by the data collection required to update the morphological modeling of the deposit, geophysical methods were introduced that made it possible to obtain reliable data on the variables of interest (including the thickness of the soil layer and the depth of the top of the bedrock). According to

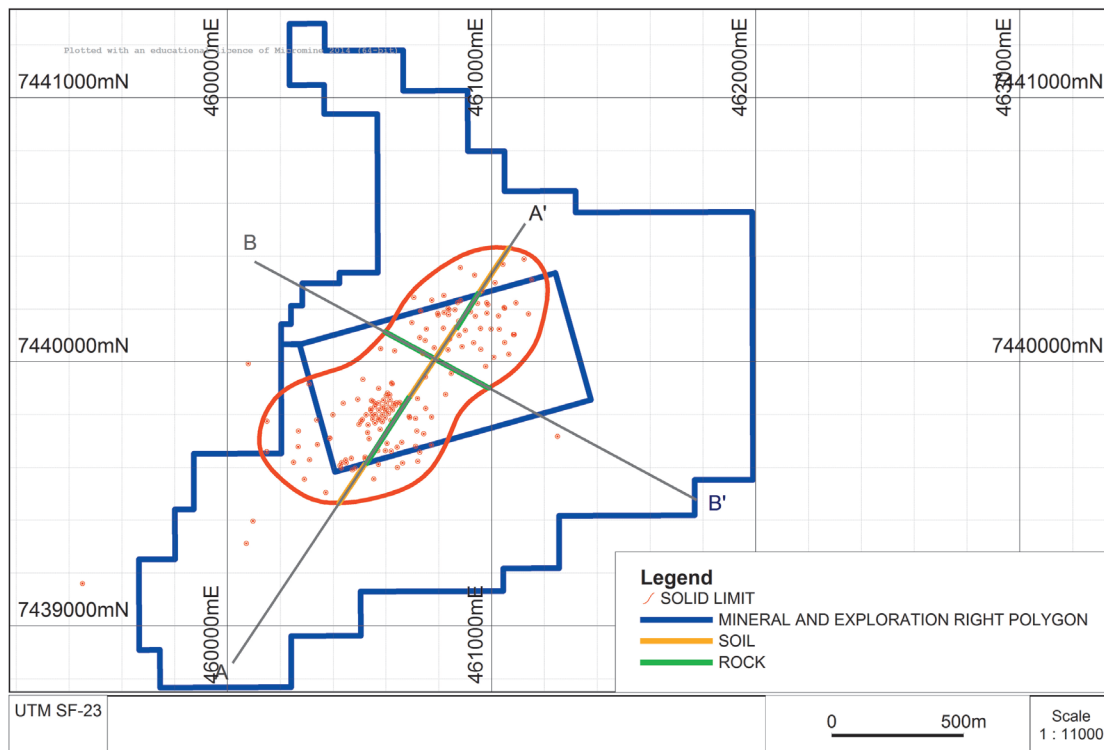

**Figure 1.** Current mining title (rectangle in the centre) with mining manifest and new title with exploration permit (external polygon).

Bery and Saad (2012), the resistivity method can be used for measuring soil electrical properties, and the ER was tested in different soil studies. Haile and Atsbaha (2014) comments that geophysical techniques are routinely used as part of geological investigations to provide information on site parameters and to map the subsurface geology and geological structures at the site. According to Ogilvy and Bogoslovsky (1979), observation of the changes in specific electrical resistivities with time on the slopes of quarries is an effective method of assessing slope stability and predicting landslide hazards.

The work began with a test to verify the accuracy of the geophysical methods used. The test was performed in the same location as an existing exploration campaign, which validated the compliance of the results of the geophysical survey with the data from drill cores. The feasibility of using the ER and induced polarization (time domain IP) methods to identify the geological contact between soil and bedrock was confirmed in this way. The technique chosen for data collection was vertical electrical sounding (VES) with a Schlumberger array. Due to the satisfactory results, 31 VESs have been planned and carried out in the southern portion of the new mining title area. Currently many surveys are performed with the VES technique. Atzemoglou *et al.* (2003) reports that a survey conducted in the NW Amynteon basin, by combining the interpretation of results of 1D VES, produced 2D and 3D results in full agreement with the local geology.

## Geophysical methods and techniques used

### *Electrical Resistivity (ER) Method*

The ER method uses an artificial electrical current that is introduced into the land through two

electrodes (known as A and B) with the aim of measuring the potential generated in two other electrodes (known as M and N) near the current flow (Elis, 1999). The introduction of an electrical current into the land through the electrodes A, B, M, and N results in a power difference ( $\Delta V$ ), thus allowing the calculation of the apparent resistivity through the equation (1):

$$\rho_a = K \frac{\Delta V}{I} (\text{ohm.m}) \quad (1)$$

Thus, it is possible to identify the different layers of soil, weathered rock, and bedrock through the resistivity values obtained in field trials.

### *Vertical Electrical Sounding (VES) Technique*

The VES technique consists of a succession of chargeability and resistivity measurements made with the same type of array and increasing separation between the emission and reception electrodes and the center of the array (allocation point test), and its orientation is kept fixed (Figure 2).

This procedure allows for the observation of apparent resistivity and chargeability values at a fixed point, at increasing depths, by increasing the separation between the current electrodes A and B. There are several electrode arrays for field trials; however, the Schlumberger array was used in this research. This array was chosen because it has a superior vertical resolution and it is able to record higher quality data (especially IP data) than other arrangements. Another important advantage over alternative arrays (such as Wenner and others) is the possibility of improving the signal to noise ratio by moving only the MN electrodes during data acquisition.

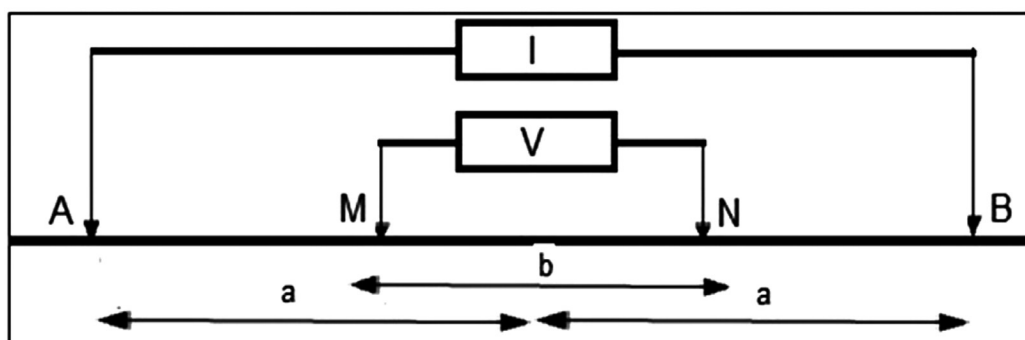

**Figure 2.** Arrangement in the field – VES Schlumberger array.

### Induced Polarization (IP) Method

IP is a phenomenon stimulated by an electric current, observed as a delayed response to voltage in natural materials (Sumner, 1976). By establishing an electrical current flow through the electrodes A and B on the surface, a primary potential difference  $\Delta V_p$  is established. A ( $\Delta V_p$ ) varies with time and acquires the shape of a curve  $\Delta VIP = f(t)$ . This curve connects the steady-state asymptote  $\Delta V_p$  with the zero asymptote after cutting the current. The method's concept is based on the amplitude of a  $\Delta VIP(t)$  value and is related to the geological material's greater or lesser capacity to polarize, therefore, the basis of the method (Figure 3).

The decay curve can be studied as a whole or just sampled at some intervals of time (Telford *et al.*, 1990).

The parameter measured in the IP (time domain) is called chargeability (M) and can be expressed in milliseconds (ms) or millivolts/volt (mV/V):

$$M = \frac{1}{V_p} \int_{t_1}^{t_2} \Delta V_{IP}(t) dt \text{ mV/V} \quad (2)$$

According to Orellana (1972), the explanation for the IP phenomenon is commonly attributed to two factors: electrode polarization and membrane polarization. In this particular case, what prevailed was membrane polarization occurring in rocks with a low content of metal elements. The changes in clay content in the different layers of soil and bedrock caused different IP responses and therefore assisted in the individualization of the layers of interest.

### Tests Conducted

Thirty-one VESs were planned and implemented in the southern portion of the exploration permit area shown on the map in Figure 4 and Table 1. According to Sahbi *et al.* (1997), when electric soundings are made over an irregular terrain, topographic effects can influence the values of apparent resistivity and lead to erroneous 1D interpretation. Due to this fact, VESs were not performed in very irregular locations to avoid this unwanted effect. VESs surveys were carried out with AB spacing varying between 200 and 500 m. The AB spacing has been adjusted according to the soil thickness. The depth of investigation was between 50 and 125 m, as shown in Table 2. The fitting errors between field data and the models varied between 2.9 and 9.4%.

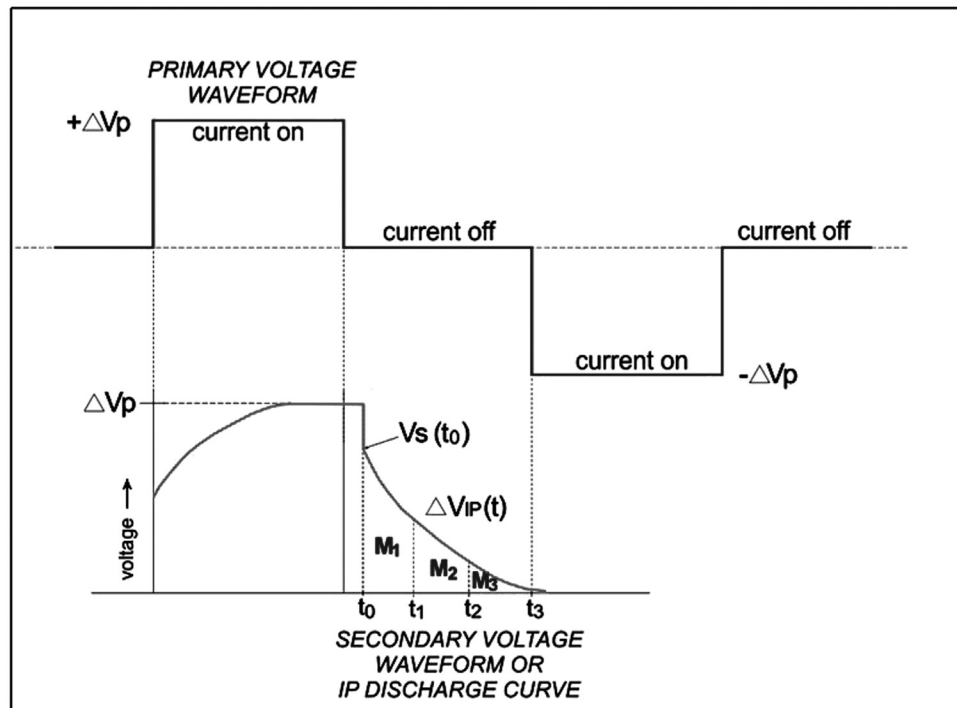
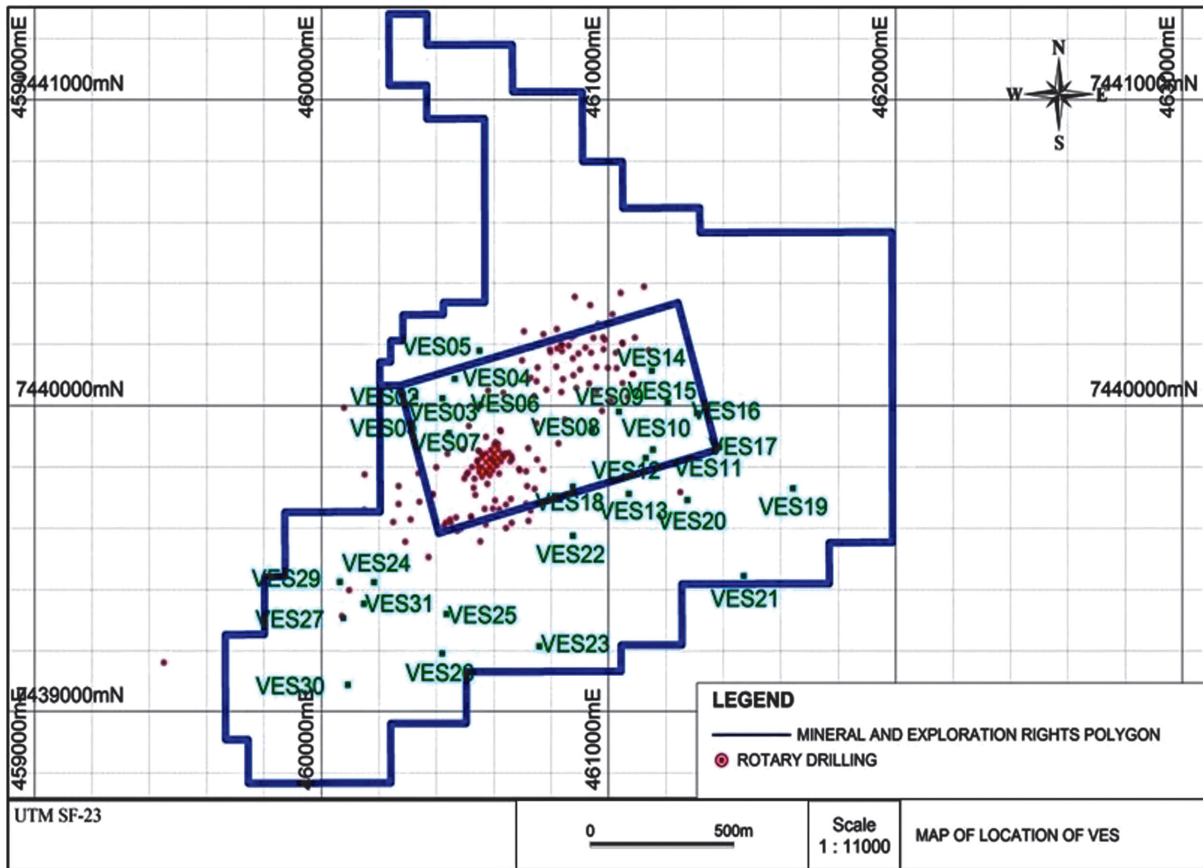

Figure 3. IP decay curve – time domain.



**Figure 4.** Location of the drill holes (as red dots) and the VESs (as green dots) within the area of interest.

**Table 1.** Coordinates of the VESs implemented in the area of interest (UTM SF-23).

Point	Coord UTM E-W	Coord UTM N-S	Point	Coord UTM E-W	Coord UTM N-S
VES 01	460272	7439974	VES 16	460272	7439890
VES 02	460292	7440072	VES 17	461323	7439776
VES 03	460390	7440046	VES 18	460810	7439708
VES 04	460440	7440103	VES 19	461562	7439608
VES 05	460530	7440217	VES 20	461193	7439613
VES 06	460465	7440008	VES 21	461365	7439346
VES 07	460394	7439931	VES 22	460776	7439552
VES 08	460889	7439888	VES 23	460622	7439201
VES 09	460991	7439935	VES 24	460080	7439474
VES 10	461093	7439772	VES 25	460318	7439337
VES 11	461153	7439735	VES 26	460283	7439194
VES 12	461063	7439772	VES 27	459959	7439368
VES 13	460999	7439659	VES 29	459962	7439499
VES 14	461111	7440079	VES 30	459948	7439144
VES 15	461163	7439947	VES 31	460036	7439407

**Table 2.** AB/2 and MN/2 spacing used during field acquisition.

AB/2	MN/2	K	AB/2	MN/2	K
1.5	0.5	6.28	30.0	2.0	703.71
2.0	0.5	11.78	40.0	2.0	1253.49
3.0	0.5	27.48	40.0	5.0	494.80
4.0	0.5	49.48	50.0	2.0	1960.35
5.0	0.5	77.75	50.0	5.0	777.54
6.0	0.5	112.31	60.0	5.0	1123.11
6.0	1.0	54.98	60.0	10.0	549.77
8.0	0.5	200.18	80.0	5.0	2020.70
8.0	1.0	98.91	80.0	10.0	989.10
10.0	0.5	313.35	100.0	5.0	3133.74
10.0	1.0	155.43	100.0	10.0	1555.09
12.0	1.0	224.51	150.0	5.0	7070.72
15.0	1.0	351.68	150.0	10.0	3518.58
15.0	2.0	173.57	200.0	5.0	12558.51
20.0	1.0	626.75	100.0	10.0	6267.47
20.0	2.0	311.01	250.0	5.0	19627.15
25.0	2.0	487.73	250.0	10.0	9801.79

In the area where the first test was conducted, the results showed that the layers of soil with higher porosity, higher clay content, and higher moisture content than the bedrock presented resistivity and chargeability values that allowed these materials to be differentiated. The VES tests were performed between the existing drill holes F02-F-121-02 and F06-F-99-03. These drill holes presented 27 to 30 m of soil on gneiss and/or weathered gneiss.

The VES results are shown in Figure 5 and Table 3 with a five-layer model. The fitting error

was 6.9%. The first four layers characterize the topsoil and weathered gneiss soil/rock. The resistivity variations reflect the changes in porosity and moisture content that are a part of the soil's profile. The gneiss presents higher resistivity (1207 ohm.m) from 24.3 m deep, which is quite consistent with data from the drill holes.

The VES surveys were performed in order to separate the soil layers from the gneiss. The soil, due to its higher porosity, higher clay content, and higher moisture content than the compact rock, tends to have lower resistivity values.

**Table 3.** VES test conducted between drill holes F02-F-121-02 and F06-F-99-03.

Layer	r (ohm.m)	M (mV/V)	Top Depth	Interpretation
1	852	3.7	0	Alteration Soil
2	1174	12	2.1	Alteration Soil
3	489	1.1	5.7	Alteration Soil
4	136	5.4	10.4	Alteration Soil
5	1207	9.8	24.3	Gneiss/weathered Gneiss

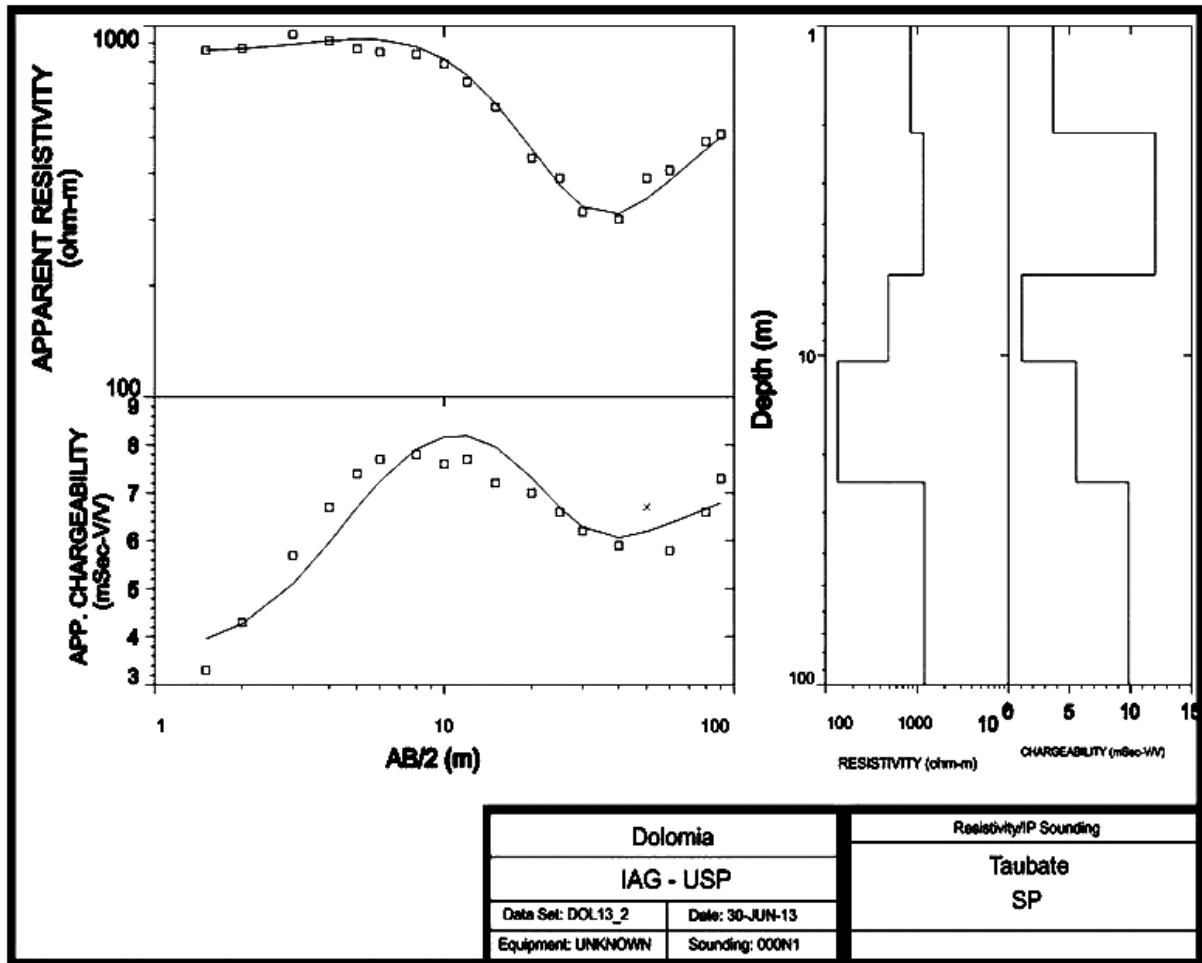

Figure 5. VES test conducted between drill holes F02- F-121-02 and F06-F-99-03.

Therefore, as resistivity is a property that responds to changes in the factors described above, it was the basis of the interpretation of the VES. According to Okay *et al.* (2013), IP is a geophysical method that is potentially sensitive to the presence of cracks in porous rocks. In this case, the chargeability data were used on a flat surface to assist in the definition of contacts and to refine the interpretation. In general, the curves show chargeability models with a higher value for the bedrock, but since this parameter is affected by small variations in the type and amount of clay minerals, some VESs showed a small decrease in chargeability for the last layer.

**Discussion of Results**

*Layer Interpretation*

The results show that it was possible to identify the layers of interest established according to the aims of the study.

Most VESs presented models of four layers. Layers 1, 2, and 3 were interpreted respectively as topsoil (low to medium resistivity, low to medium chargeability), unsaturated alteration soil (high resistivity due to low moisture content and medium chargeability), and saprolite or alteration soil (low to medium resistivity and low chargeability). The fourth layer typically showed high resistivity values (greater than 2000 ohm.m) and higher chargeability (typically above 10 mV/V) and was interpreted as bedrock gneiss. Higher resistivity values are expected for gneiss due to the low degree of alteration and low porosity. The larger chargeability values may be related to accessory metallic minerals in the gneiss, which have not yet been processed by weathering conditions.

To illustrate these results, Figure 6 and Table 4 summarize the geo-electrical model of VES 10 with the succession of layers of soil above the bedrock gneiss.



In the data concerning VESs 05, 06, 24, 27, and 28, resistivity values below 1000 ohm.m were observed for the last layer, which is interpreted as saprolite or weathered gneiss. These relatively low values suggest a rock with some degree of alteration and/or fracturing.

Another VES with results that clash with the other models is VES 19, where the resistivity of the layer above the layer interpreted as bedrock is relatively high (greater than 2000 ohm.m). Here it is possible that the third layer is characterized by a slightly weathered or fractured rock.

Figure 7 and Table 5 present the geo-electrical model for VES 05, in which the fourth layer is characterized as saprolite or weathered gneiss.

**Table 4.** VES 10 with a succession of soil layers on top of the bedrock.

Layer	r (ohm.m)	M (mV/V)	Thickness (m)	Top Depth	Interpretation
1	37.4	0.3	0.5	0.0	Top soil
2	2270.9	8.3	2.3	0.5	Unsaturated soil
3	96.5	4.2	2.5	2.9	Low saturated soil/saprolite
4	7633.5	29.6		5.4	Gneiss

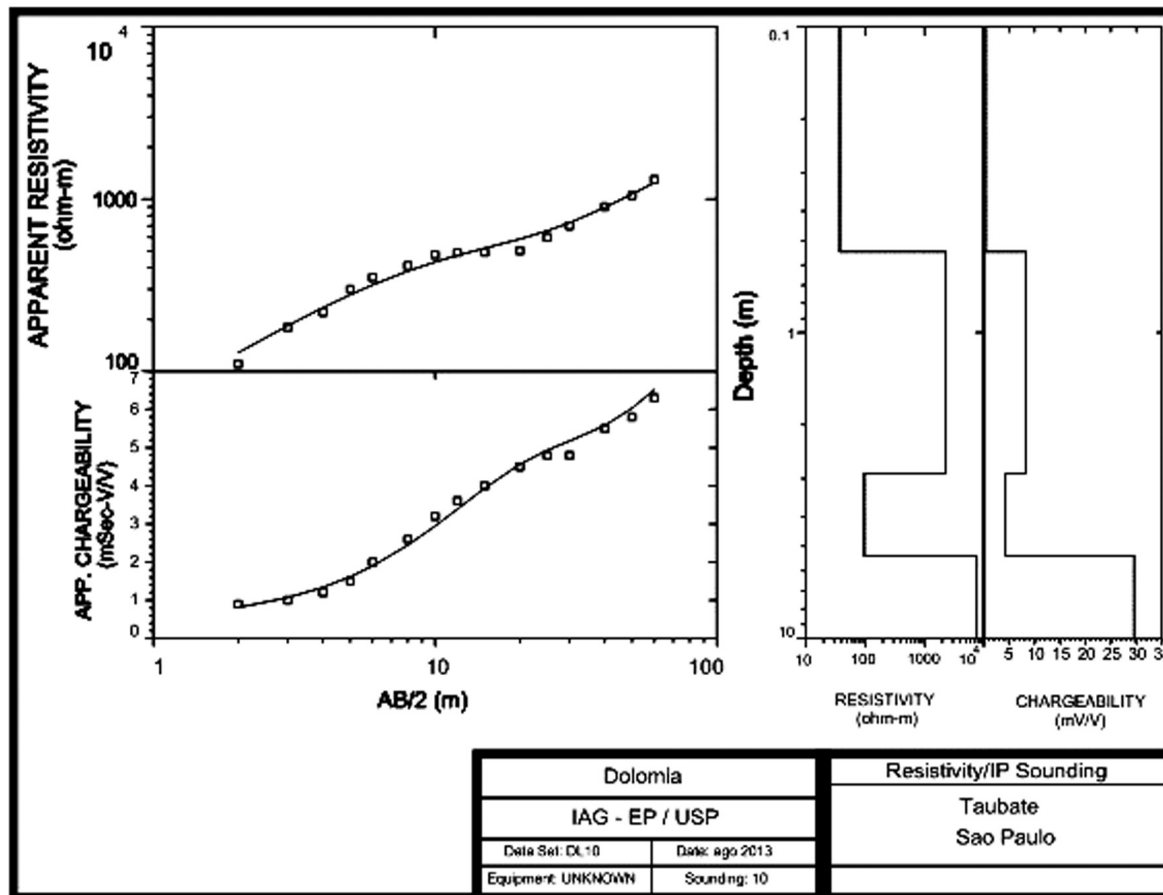

**Figure 6.** Geo-electrical model of VES 10.



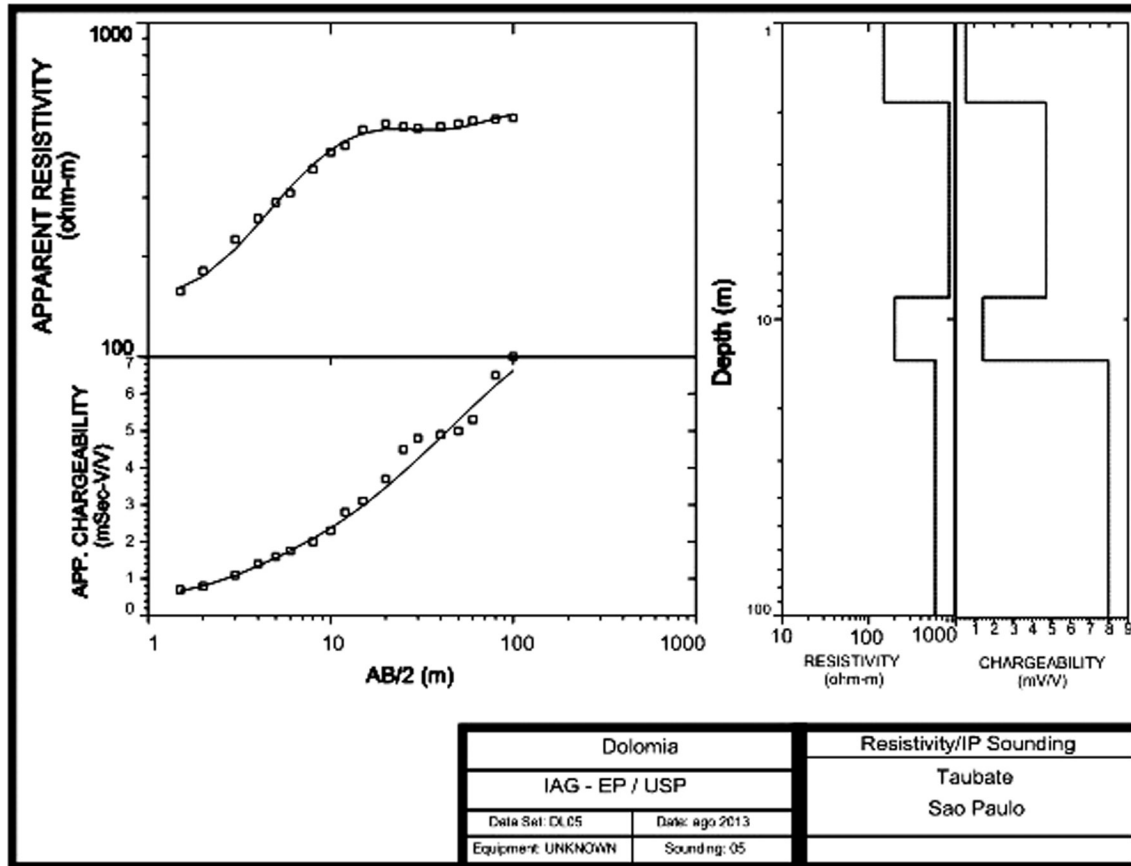

Figure 7 – Geo-electrical model of VES 05.

Table 5. VES 05, in which the fourth layer is characterized as saprolite or weathered gneiss.

Layer	r (ohm.m)	M (mV/V)	Thickness (m)	Top Depth	Interpretation
1	148.8	0.5	1.9	0	Top soil
2	851.6	4.7	6.6	1.9	Unsaturated soil
3	198.8	1.4	5.3	8.4	Low saturated saprolite/soil
4	585.9	8		13.8	Saprolite/weathered gneiss

*Morphological Model Update*

Table 6 shows the interpreted depth of the rock top, which was used for updating the morphological model.

The interpreted data of the top of the rock layer in all VESs conducted in the area of interest were used to update the morphological model of the area.

Figure 8 shows the geological sections across the updated morphological model. Figures 9 and 10 show the geological sections AA' and BB' with the original model and the expanded interpretation using data from VESs.

**Table 6.** Interpreted depth of the bedrock contact for updating the morphological model.

Point	Rock top depth (m)	Point	Rock top depth (m)
VES 01	18.20	VES 16	15.10
VES 02	11.80	VES 17	17.90
VES 03	26.10	VES 18	8.60
VES 04	8.60	VES 19	17.00
VES 05	13.80	VES 20	26.80
VES 06	21.00	VES 21	18.60
VES 07	26.30	VES 22	24.00
VES 08	34.50	VES 23	24.40
VES 09	28.50	VES 24	11.40
VES 10	5.40	VES 25	16.60
VES 11	7.20	VES 26	35.60
VES 12	7.20	VES 27	7.40
VES 13	38.40	VES 29	8.80
VES 14	16.00	VES 30	8.30
VES 15	13.20	VES 31	7.20

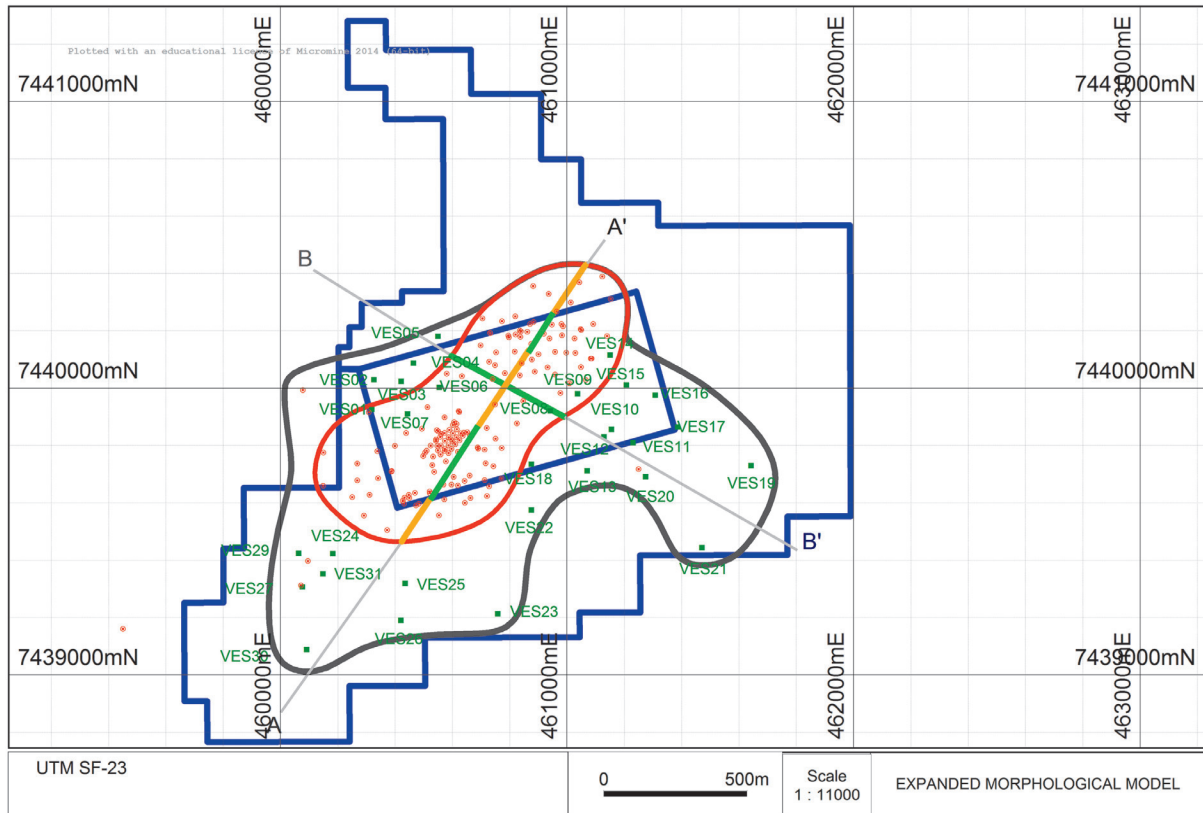

**Figure 8.** Position of the geological sections across the updated morphological model.

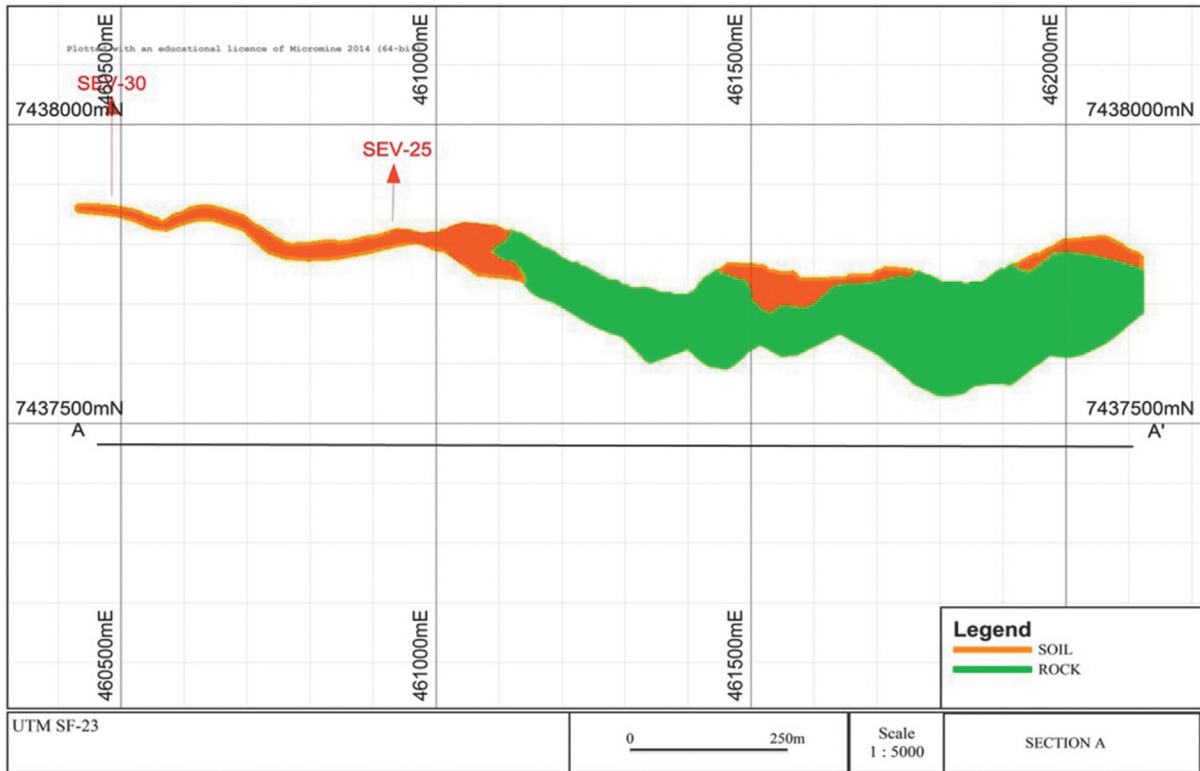

Figure 9. Geological section AA'.

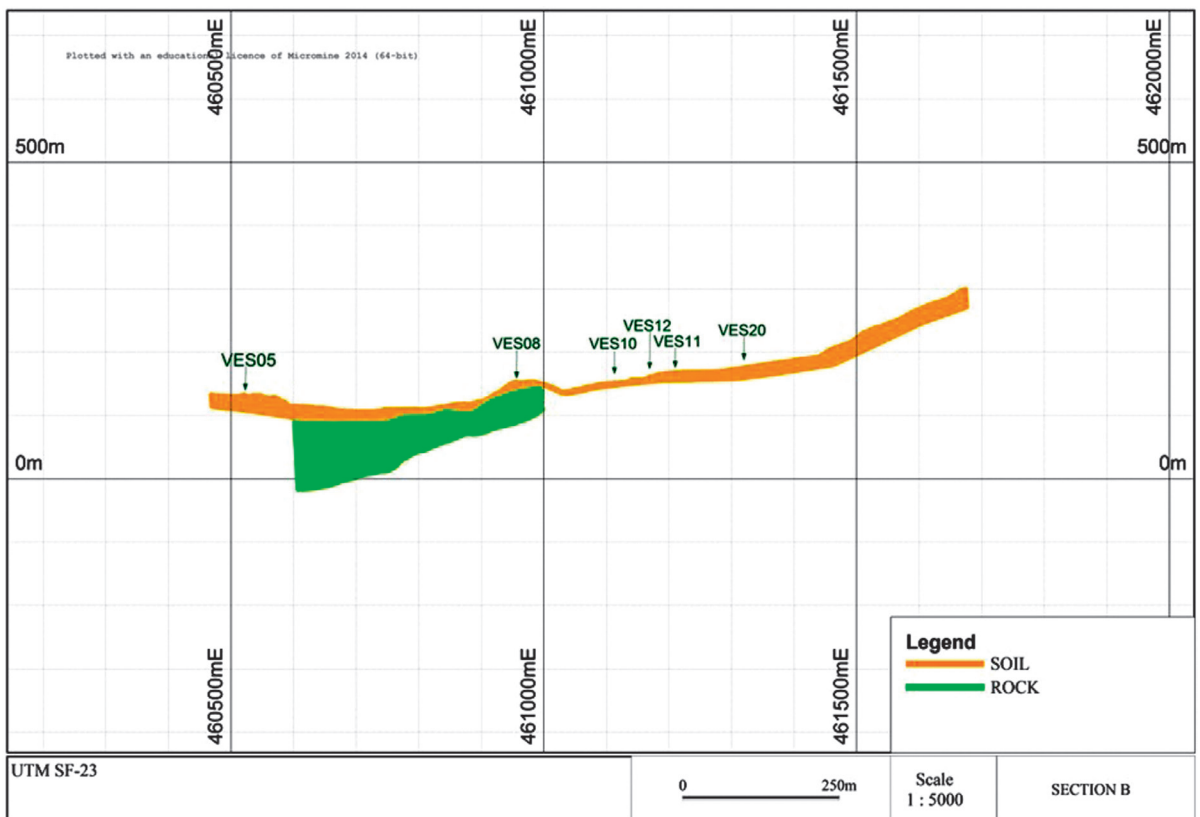

Figure 10. Geological section BB'.

## Conclusion

The geophysical study carried out allowed the efficient expansion of the morphological model of the deposit within the exploration permit area, taking into account the aims established:

- to interpret, with adequate accuracy, the lithological units of interest (soil layer depth and the contact between soil and bedrock)
- to carry out the exploration campaign in the entire area of interest within the deadlines set by the company.

The study results show that the geophysical methods proposed in this paper can be used to determine the thickness of the soil layer on the top of the bedrock and to identify the layers of interest. That is, this research has proved that geophysics can improve the level of geological knowledge for morphological modeling purposes and its application has the potential to be extended and increased within the associated activities in the mine planning cycle of a mining operation.

In practical terms, the introduction of the proposed geophysical methods and techniques allowed the gathering of information necessary for updating the morphological model, which would normally have been carried out in approximately 60 days (using between three and four drilling equipment), in 15 days, which means a 70% reduction in the work time.

It is suggested that some drill holes are carried out right next to the VESs that showed low resistivity of the gneiss to validate the interpretation of this particular lithology.

It is likely that some differences in position between the interfaces defined by geophysics and the drill holes should occur. This can be explained by the limitations of the methods and geophysical techniques in the identification of contact within highly irregular topography.

## Acknowledgements

The authors are grateful for the support provided by to FAPESP (Foundation for Support to the Research of the State of São Paulo, Brazil), CNPq (National Counsel of Technological and Scientific Development, Brazil) and Micromine Pty Ltd. (Australia).

## References

Atzemoglou A., Tsourlos P., Pavlides S., 2003, Investigation of the tectonic structure of the NW part of the Amynteon Basin (NW Greece) by means of a Vertical Electrical Sounding

(VES) survey. *J. Balkan Geophys. Soc.*, 6, 4, 188–201.

Bery A.A., Saad A. 2012, Tropical clayey sand soil's behaviour analysis and its empirical correlations via geophysics electrical resistivity method and engineering soil characterizations. *International J. Geosci.*, 3, 111–116, Scientific Research.

Elis V.R., 1999, Avaliação da aplicabilidade de métodos elétricos de prospecção geofísica no estudo de áreas utilizadas para disposição de resíduos. Tese de Doutorado, Instituto de Geociências e Ciências Exatas, UNESP, Campus de Rio Claro-SP, 264 p.

Frasheri A., Lubonja L., Alikaj P., 1995, On the application of geophysics in the exploration for copper and chrome ores in Albania. *Geophys. Prospect.*, 43, 6, 743–757.

Haile T., Atsbaha S., 2014, Electrical resistivity tomography, VES and magnetic surveys for dam site characterization, Wukro, Northern Ethiopia. *J. African Earth Sci.*, 97, 67–77.

Ogilvy A.A., Bogoslovsky V.A., 1979, The possibilities of geophysical methods applied for investigating the impact of man on the geological medium. *Geophys. Prospect.*, 27, 4, 775–789.

Okay G., Cosenza P., Ghorbani A., Camerlynck C., Cabrera J., Florsch N., Revil A., 2013, Localization and characterization of cracks in clay rocks using frequency and time domain induced polarization. *Geophys. Prospect.*, 61, 1, 134–152.

Orellana E., 1972, *Prospeccion Geoelectrica en Corriente Continua*. Ed. Paraninfo, Madrid, 523 p.

Ravindran A.A., 2010, Characterization of the geology of subsurface shallow conglomerate using 2D electrical resistivity imaging at Baragadi, Panna District, Madhyapradesh, India. *J. Appl. Sci. Environ. Manag.*, 14, 3.

Sahbi H., Jongmans D., Charlier R., 1997, Theoretical study of slope effects in resistivity surveys and applications. *Geophys. Prospect.*, 45, 5, 795–808.

Sumner J.S., 1976, *Principles of Induced Polarization for Geophysical Exploration*. Elsevier Scientific Publishing Co., Amsterdam, 227 p.

Telford W.M., Geldart L.P., Sheriff R.E., 1990, *Applied Geophysics*. Cambridge University Press, Cambridge, 770 p.