

A general model for tectonic control of magmatism: Examples from Long Valley Caldera (USA) and El Chichón (México)

M. Bursik

Department of Geology, State University of New York at Buffalo, Buffalo, New York. USA

Received: July 24, 2008; accepted: November 15, 2008

Resumen

La relación entre la presencia de volcanes, el marco tectónico regional y la dinámica de los temblores es muy estrecha. Sabemos que las erupciones son a menudo disparadas por temblores y que los volcanes generalmente se levantan a lo largo o cerca de grandes fallas, o en medio de provincias que han experimentado alto grado de fallamiento. En general se ha observado que el volcanismo bimodal basáltico-reolítico está asociado a un marco extensional, probablemente debido a la creación en los mismos de espacios de acomodamiento. Para volcanes intermedios en un arco volcánico el régimen tectónico es generalmente compresional o transpresional. Para Long Valley el patrón espacial de fallamiento indica que su generación fue facilitada por la relajación debida a un doblez en el sistema transtensional de fallas frente-de-sierra-coordillera. El patrón temporal en la tasa de corrimiento sugiere que la zona de mayor actividad ha migrado con el tiempo hacia el NW y se encuentra ahora enfocado en los cráteres Mono-Inyo. El arco volcánico mexicano del Sur presenta un ejemplo de la coexistencia entre volcanes y estructuras compresionales y transpresionales. El corrimiento entre estructuras regionales ofrece la oportunidad para que se de el movimiento del magma y su eventual erupción, en una especie de bombeo de fluidos a través de fallas dinámicas. Tanto cinemática como dinámicamente, la actividad volcánica puede ser completamente dependiente de factores tectónicos para la acumulación, el almacenamiento y la erupción del magma.

Palabras clave: Caldera Long Valley, arco volcánico chiapaneco, control tectónico del volcanismo, tectónica y magmatismo, fallamiento en ambientes volcánicos.

Abstract

The relationship of volcanoes to regional tectonic setting and earthquake dynamics is intimate. We know that eruptions are often triggered by earthquakes, and that volcanoes generally lie along or near major faults or within faulted provinces. It has been generally found that bimodal basaltic-rhyolitic volcanism is associated with extensional settings, presumably because of the creation of accommodating space. For intermediate arc volcanoes, tectonic settings are generally compressional or transpressional.

The spatial pattern of faulting indicates that Long Valley was focussed by a releasing bend in the transtensional, Sierran range-front fault system. The temporal pattern of offset rates suggests that the zone of greatest activity has migrated to the NW through time, and is now focussed at the Mono-Inyo Craters. The southern Mexican volcanic arc presents an example of the coexistence of regional compressional and transpressional structures with volcanoes. On an event basis, slip on regional structures creates opportunities for magma movement and eruption, in a type of dynamic fault pumping of fluids. Both kinematically and dynamically, volcanic activity may be completely dependent on tectonic factors for accumulation, storage and eruption of magma.

Key words: Long Valley Caldera, Mono-Inyo Craters, El Chichón, California, Mexico, dike, releasing bend, pull apart, volcanotectonic, regional tectonics.

Introduction

The relationship of volcanoes to regional tectonic setting and earthquake dynamics is intimate, yet presents a complex problem owing to contrasts in scale and material properties. We do know that eruptions are often triggered

by earthquakes, and that volcanoes generally lie along or near major faults or within heavily faulted provinces (Bautista *et al.*, 1996; Linde and Sacks, 1998; Hill *et al.*, 2002; Spinks *et al.*, 2005; Manga and Brodsky, 2006).

It has been generally found that bimodal basaltic-

rhyolitic volcanism is associated with extensional settings, presumably because of the creation of accommodating space by crustal stretching (Lipman *et al.*, 1972). For intermediate arc volcanoes, tectonic settings are generally compressional or transpressional (Lipman *et al.*, 1972; Nakamura *et al.*, 1977; Guzmán-Speziale and Meneses-Rocha, 2000). It has been pointed out though that just as much space can be created in the compressional setting native to andesitic stratovolcano volcanism; it is just created in a different geometry (Cambray *et al.*, 1995). Ashflow calderas are typical of many bimodal volcanic fields, and are locally present in arcs. Ashflow calderas are the largest single-event volcanic structures on earth, representing the eruption of up to 1000's km³ at a time. Despite their phenomenal size, and the associated need for creation of vast amounts of crustal space, the classical model of ashflow calderas contains no information about their relationship to regional geologic features (Fig. 1). Yet we can ask: How does the caldera structure relate to regional structures and tectonics? How can such a vast amount of material accumulate? How is an eruption initiated?.

Proximity in both space and time suggests that some measure of the rate of volcanic activity should be relatable to the rate of tectonic activity. This observation, in turn, indicates that where either tectonic or volcanic rate is unknown, it can be inferred from the other. Volcanoes occur in both tensional and compressional tectonic settings – the intraplate bimodal basaltic-rhyolitic provinces and plate boundary andesitic arcs. In the transtensional setting of Long Valley caldera-Mono-Inyo Craters, it has been shown that the rate of volcanic activity (as measured by the intrusion rate of dikes) can be related directly to the extension rate (Bursik and Sieh, 1989). In compressional and transpressional settings, the relationship is less fully explored, for example in Sumatra (Sieh and Natawidjaja, 2000), but there is evidence that regional tectonic strains are related to volcano deformation, instability and magmatic intrusion (Nakamura *et al.*, 1977; Lagmay *et al.*, 2000, 2005).

In the present contribution, we give anecdotal evidence that can be used to investigate the hypothesis that caldera formation results from (trans)tensional tectonics and that stratovolcano formation results from (trans/com)pressional tectonics. As a corollary, we also investigate evidence that ascent and eruption happen ultimately, only as a stress relief mechanism (Vigneresse and Clemens, 2000). In contrast, previous models of eruption have relied on active, buoyant rise of magma through the shallow crust. Because datasets are not exhaustive, examples are shown of how transtension and transpression provide unique and exceptional opportunities for both accumulation and eruption of large quantities of magma. We argue that concentrated, large scale volcanism is related to the tectonically focussed, controlled accumulation and storage of magma in releasing structures that are themselves ideally oriented for eruption or that are associated with such structures. Much of the paper is review, of necessity. However, new information on the Long Valley region is also brought forth.

Tectonic focussing of intraplate volcanism

Intraplate volcanism is dominated by widespread basaltic volcanic fields (Lipman *et al.*, 1972). Many fields develop a central area of evolved magma, often including a large-volume ashflow caldera. Although the close association between basaltic volcanic fields and regional faults has been noted, the factors causing suppression or development of the caldera are not understood. The original articulation of the traditional model of ashflow caldera formation was enunciated by Smith and Bailey (1968) (Fig. 1). It has most recently been recast by Lipman (1997) and Cole *et al.* (2005). Only in the most recent work of Cole *et al.* does this standard model contain information on the link between the caldera and regional faults, despite the observation that ashflow calderas invariably occur in profoundly faulted crust and are of the same scale (10s of km) as regional fault segments. We can look at the problem of volcanic field and potential caldera development in relation to regional tectonics from the

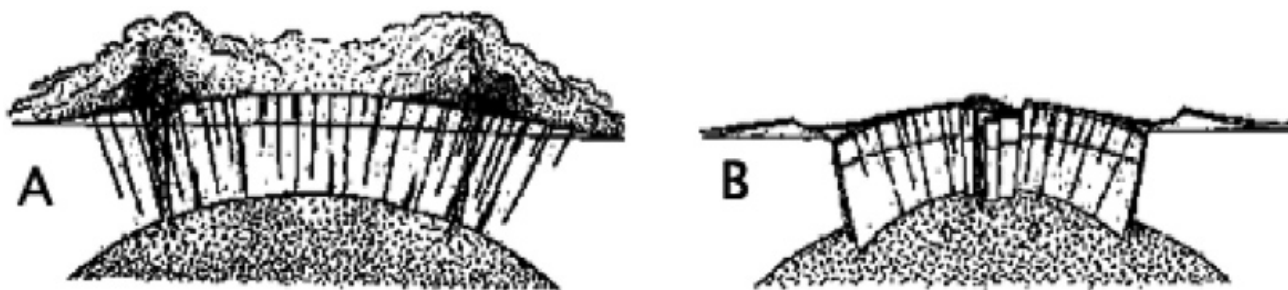

Fig. 1. The traditional model for ashflow caldera volcanism (modified from Smith & Bailey, 1968). a) Eruption of ash flow along circular ring fractures above a large coherent magma chamber. b) Collapse of cauldron block along subvertical ring faults developed from eruptive fractures.

standpoint of both large-scale kinematic development as well as small-scale dynamic development (event basis).

Kinematics

Recent studies of the emplacement of granitic plutons suggest a close relationship between regional faults and pluton location. Structural as well as petrological studies both show that some granitic plutons are emplaced in tectonic 'holes', pull aparts or extensional zones within regional strike-slip fault systems (Fig. 2) (Cambray *et al.*, 1995; Vegas *et al.*, 2001). The plutons grow by granitic sheeting -the incremental addition of magma by extension at releasing areas, and subsequent storage (Figs. 3, 4) (Hutton, 1992; Hutton and Reavy, 1992). Recent high-precision plutonic dating supports the idea of growth of plutons by sheeting (Coleman *et al.*, 2004). In their study of the Tuolomne Intrusive Suite, perhaps the best-known of all Sierran rocks, Coleman *et al.* found diachronous dates within the suite and within individual plutons, from younger in the core to older in the outer zones. If plutons develop in a local extensional tectonic environment, then it is natural to assume that the volcanoes above them will also form in relation to the tectonic environment. The relationship will not be exactly the same, since a volcano represents the response of the crust above the

level of the pluton. We can investigate the Long Valley-Mono-Inyo Craters volcanic field to try to understand the relationships.

It may be that the Bishop Tuff magmatic system developed in a pull apart basin (Fig. 5). The lavas of Long Valley represent the tectonically localized, evolved products of a widespread region of Plio-Pleistocene basalts (Bailey *et al.*, 1976; Metz and Mahood, 1985).

The Long Valley lavas were localized in a tectonic setting dominated by long range front fault segments with large vertical throws. The main range-front fault to the south of the caldera is the Hilton Creek Fault, with some strain accommodated by the Casa Diablo Mountain Fault. North of the caldera, the fault system is more complex, but three faults Sagehen Peak, Hartley Springs and Silver Lake – accommodated most of the crustal stretching in this region prior to caldera formation. As with these faults in more recent times, data indicate there may have been a right-lateral component to fault movement on NNW-trending faults. Gilbert *et al.* (1968) document an unknown but significant amount of apparent right-lateral offset of the contact between 12 m.y. andesite and Cretaceous granites along the Cowtrack Mountain Fault.

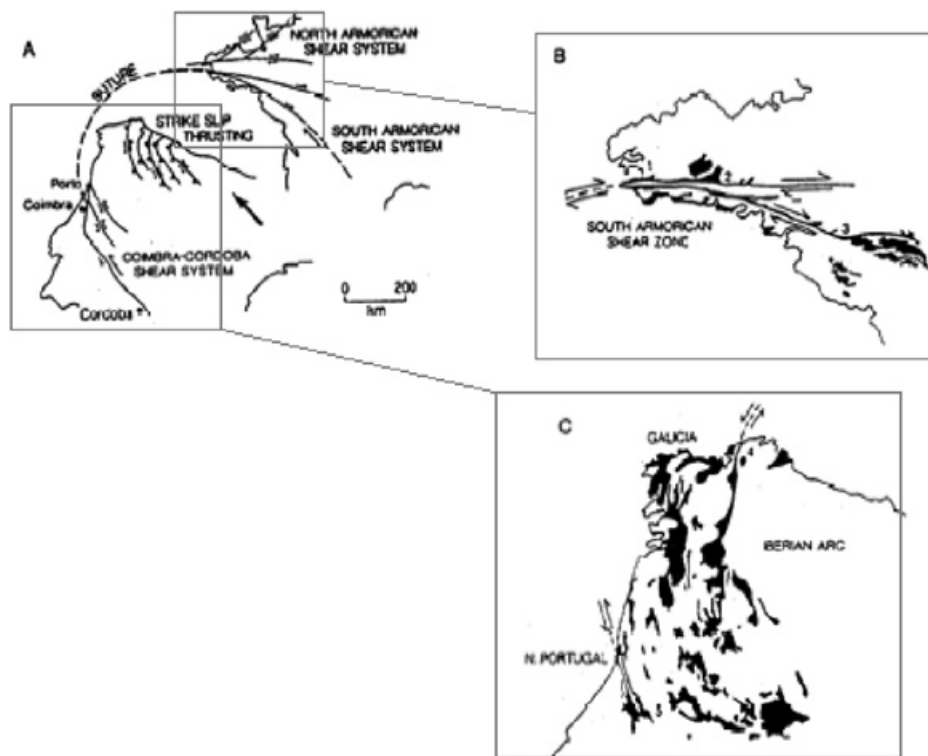

Fig. 2. Emplacement of plutons of the Ibero-Armorican shear system in association with strike-slip tectonism (modified from Hutton and Reavy, 1992).

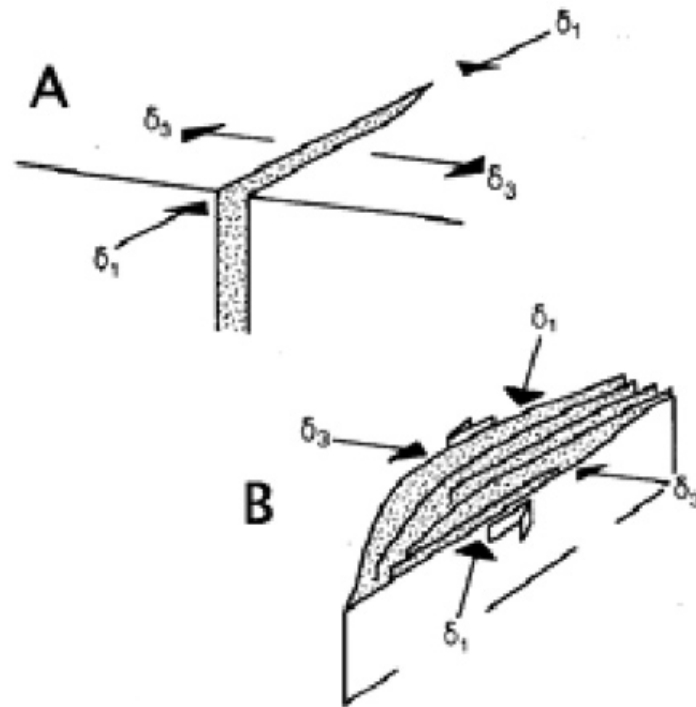

Fig. 3. Growth of plutons by granitic sheeting (modified from Hutton, 1992) in: A) Andersonian dike, B) transcurrent faulting system.



Fig. 4. Storage of evolved melt in releasing bends in different regional tectonic settings, Southwest Nevada Volcanic Field (modified from Cambray *et al.*, 1995). A) strike-slip, B) normal, C) reverse.

Average pre-caldera vertical movements on these major faults can be estimated from previously published material (Rinehart and Ross, 1964; Huber and Rinehart, 1965; Gilbert *et al.*, 1968; Krauskopf and Bateman, 1977). Vertical offset rates estimated from these data suggest that the dilational jog between the Hilton Creek Fault and the Sagehen Peak Fault, filled with intrusions from the Bishop Tuff/Glass Mountain magma chamber, took up the regional extension within what was to become Long Valley caldera directly prior to caldera formation (Fig. 5).

The outcrop pattern of Glass Mountain vents does not however indicate a tectonically aligned source similar to that for the Mono-Inyo chain (Metz and Mahood, 1985). It may be that the presently exposed pattern of domes

is a remnant of a complex network of dikes and faults, covering most of the area within the jog, which evolved from a simple aligned geometry resembling that of the Mono Craters. When the Bishop Tuff/Glass Mountain magma chamber was sufficiently large, the orientation of dikes intruded into the crust above it was controlled by stresses associated with the magma chamber itself, in addition to regional stresses.

Geological and geophysical evidence indicates that the hypothesized, pre-existing pull apart guided the eruption of the Bishop Tuff and caldera subsidence (Fig. 5). Venting of the Bishop Tuff began near the intersection of the Hilton Creek and the Casa Diablo Mountain Faults (Hildreth and Mahood, 1986). The eruption then followed these bounding faults to the north until it terminated near

the intersection with the Sagehen Peak range-front north of Glass Mountain. Gravity data furthermore show that the bounding structures of the entire main subsided cauldron block follow the trends of the faults that would outline the Glass Mountain dilational jog (Carle, 1988).

As the Long Valley magma chamber was evacuated, the collapse of the caldera itself should have responded to the tectonic setting. We consider the geometry of the extensional faults at depth, as well as the nature of the stresses on the faults. It is well-documented that many of the extensional structures of the Basin Ranges are detachment, or low-angle normal faults (Wesnously and Jones, 1994; Cichanski, 2000). As discussed above, gravity data show that the greatest subsidence of Long Valley Caldera was at its eastern margin (Fig. 5) (Carle, 1988); thus the original evacuated magma chamber was in that same area. The subsided block contains approximately 3 km of fill. Several geophysical datasets and methodologies are all consistent with a currently active

magma system between 5 and 8 km depth underneath the resurgent dome (Hill, 2006). The surface rupture of the western margin of the caldera is on average approximately 15 km to the west of the region of deepest subsidence. Using the geometry of a magmatic system of 3 km depth between 5 and 8 km beneath the surface, and a distance to the western margin of 15 km, the average dip of the slip surface between the western caldera margin and the cauldron block is only ~10-15 degrees. This is a low-angle (detachment) structure. Subsidence of the caldera along an east-dipping detachment fault soling in a cauldron block on the eastern caldera margin may be consistent with the northward extension of the batholith bounding East Sierran Thrust System at least to the latitude of Long Valley (Wernicke *et al.*, 1988). Thus, the most reasonable structural solution to caldera subsidence is not consistent with slip on high-angle faults, but rather on east-dipping low-angle reactivated structures. In this scenario, the northern and southern margins of the caldera then are regions primarily of strike-slip motion on faults that sole

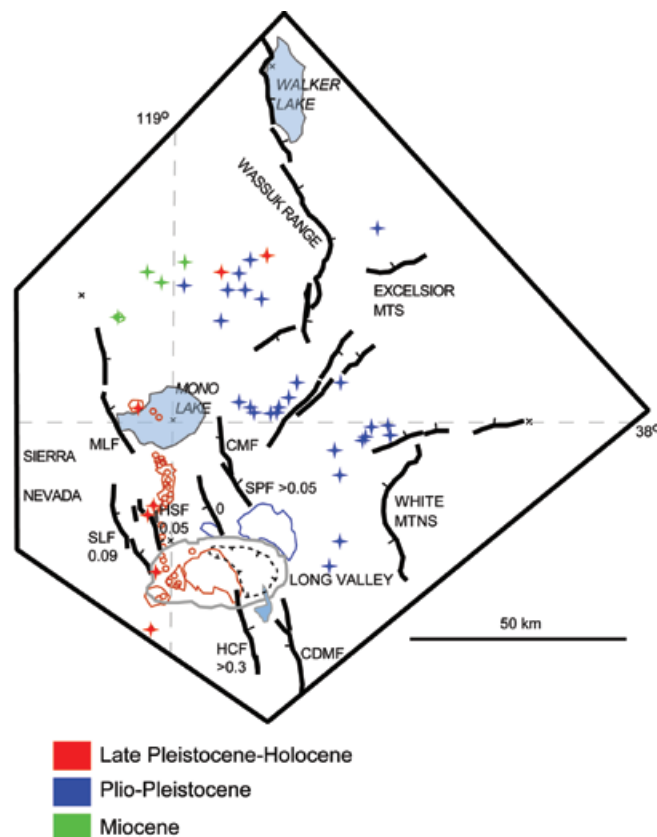

Fig. 5. Regional tectonic setting of Long Valley caldera, CA/NV. The caldera occurs in a region of transtensional tectonics related to Walker Lane and the Eastern California Shear Zone. Major range bounding faults are bold. Vertical component of motion is shown. NNW trending faults in addition have a variable component of right-lateral motion, and NE trending faults have a left-lateral component of motion (Bursik and Sieh, 1989). Numbers next to faults are rates of vertical slip (mm/yr) averaged through the time interval bracketing or ending with eruption of Bishop Tuff. Area of maximum caldera subsidence (~3 km) shown in dashed line (from Carle, 1988). Ages of volcanic vents shown in colors; types of vents with symbols: cross, basaltic; circle, evolved. Some areas of larger outcrop are shown in outline. MLF, Mono Lake Fault; CMF, Cowtrack Mountain Fault; SLF, Silver Lake Fault; HSF, Hartley Springs Fault; SPF, Sagehen Peak Fault; HCF, Hilton Creek Fault; CDMF, Casa Diablo Mountain Fault. Scale and orientation are approximate as map is made from uncorrected Shuttle Large Format Camera images.

into the detachment surface. There is then the possibility that the ubiquitous low-angle detachment faults of the Basin Ranges also play some role in caldera formation, as well as re-activation of former compressional structures in the current extensional regime.

The Mono Craters magma system has also been considered to be forming in a releasing bend similar to the tectonic holes in which granitic plutons have been thought to occur (Bursik and Sieh, 1989). The Mono magma chamber lies at a depth of 8 to 15 km (Achauer *et al.*, 1986). It may enlarge by the incremental injection of dikes along one extending wall of the releasing bend, suppressing tectonic movement along the nearby range-front fault. This relationship provides some evidence for a suppression of tectonic topography by volcanic activity (Parsons and Thompson, 1991). One result of the tectonic/topographic suppression is that in the immediate vicinity of volcanoes (to 10s of km), there is relatively little evidence of tectonism. The apparent migration of the center of activity of the evolved magmatic system from Long Valley to the Mono Craters during Quaternary time is consistent with the northwest migration of the focus of tectonic activity suggested by the dated fault slip rate patterns. The overall outcrop pattern of volcanic vents in the entire region also shows this trend (Fig. 5).

Event scale dynamics.

On the event or eruption scale, we must consider the dynamic states of stress on the faults in a volcanic region. Stratigraphic data suggest that during the North Mono-Inyo eruption sequence of c. 1350 A.D. a series of strong earthquakes occurred near the end of the North Mono explosive phases and the beginning of the Inyo explosive phases (Bursik *et al.*, 2003). Geological and geomorphic features of the Hartley Springs Fault are consistent with rupture of the fault during the eruption sequence (Fig. 6).

The indication is that the Inyo Dike, found by drilling underneath the main Inyo vents, neared the Hartley Springs Fault as it propagated southward from the Mono Basin ~1350 A.D. Once the lateral distance between dike and fault was sufficiently small, the mechanical interaction between them is thought to have triggered the slip observed on the fault. The slip, in turn, reduced the horizontal confining pressure in a region near the southern tip of the fault. The presence of the main Inyo vents in this region suggests that the reduction in confining stress was sufficient to allow magma to propagate to the surface and erupt, in a type of "fault pumping" mechanism (Fig. 7) (Bursik *et al.*, 2003). The resulting volcanotectonic 'cascade' of eruptions and earthquakes thus activated a large section of the range front stress relief system

because of the positive feedback provided by each element to continued activity. In the kinematic interpretation of fault and dike relationships between the Mono and Inyo chains and the range front fault system, Bursik and Sieh (1989) hypothesized that either dikes or faults accommodated regional extension at any one position along the Sierran range front. The dynamic analysis of dike propagation suggests that the relationship between the two mechanisms is somewhat more complicated, and that the two mechanisms for accommodation of crustal stretching might interact locally. One recently documented example of this in the continental arc environment comes from Karimskiy volcano, Kamchatka (Walter, 2007). There too, a low-confining pressure area at a fault tip was dynamically created in which magma rose to the surface and erupted.

Tectonic focussing of arc volcanism

The southern Mexican volcanic arc in the region of El Chichón presents a striking example of the coexistence of lateral and compressional structures with arc volcanics (Fig. 8). The left-lateral Motagua-Polochic Fault System has long been recognized as a major strike-slip structure associated with the North American-Caribbean plate boundary (Malfait and Dinkelman, 1972). North of the Motagua-Polochic System, the Strike-slip Fault Province was also recognized as a region of active strike-slip tectonism (Guzmán-Speziale *et al.*, 1989). Recently, the Chiapas Anticlinorium Reverse Fault Province has been recognized as a constraining bend between the Motagua-Polochic Fault and the Tecpatan-Ocosingo Fault Strike-slip Fault Province (Guzmán-Speziale and Meneses-Rocha, 2000).

El Chichón lies within the Chiapanecan Volcanic Arc (CVA), a 150-km long string of volcanoes between the Trans-Mexican Volcanic Belt and the Central American Volcanic Arc (Mora *et al.*, 2007). The central CVA is comprised of at least ten polygenetic volcanic edifices localized on (rotated?) Reidel structures splayed from the Motagua-Polochic System. Although the local kinematics is not well-known, some of the volcanoes of the CVA are clearly localized at tensional junctures in the fault system. Volcanic rocks in the CVA are as old as 2.2Ma, suggesting to Damon and Montesinos (1978) that the CVA formed as the result of a change in the direction of relative movement of the Cocos Plate at c. 2.8Ma.

Within this larger setting, El Chichón has been found to be situated at the tip of the San Juan Fault within the Strike-slip Fault Province, on the releasing side of the fault tip (Fig. 9), perhaps even in a small, active pull-apart basin (García-Palomo *et al.*, 2004). Volcanism has

been focussed at this spot for at least $\sim 280\text{ka}$ (Tilling *et al.*, 1984), making it a site of quite long-lived volcanic activity. Thus, although the tectonic province is overall transpressional, magma is able to be erupted at the surface given a local extensional setting, not only at El Chichón, but elsewhere within the arc. The setting is in fact analogous to that of the Inyo Craters. The analysis of the regional tectonic setting by García-Palomo *et al.* (2004) thus suggests that not only on the dynamic event scale related to fault pumping (as at Inyo Craters and Karimskiy) but also at the long-term kinematic scale a localized site of tension is a favorable setting for volcanic eruption. It may be significant that this particular setting for the surface expression of magmatism is common to both compressional and tensional regional tectonics.

Volcanotectonic evolution from arc to ashflow

The interior western cordillera of North America has evolved from andesitic arc to basalt-rhyolite magmatism at the same time as evolving from the compressional tectonics of the Laramide Orogeny to the current extension (Lipman *et al.*, 1972; Coney and Harms, 1984). A compilation of past studies of tectonism and magmatism within the more confined region of the eastern Sierra Nevada range front suggests that throughout Neogene time, the southern limit of arc magmatism propagated northward through the region (Fig. 10). The northern limit of basalt/ rhyolite association followed in the wake of the arc. Extensional tectonics also postdates arc magmatism. Only locally however has basalt/rhyolite association led to

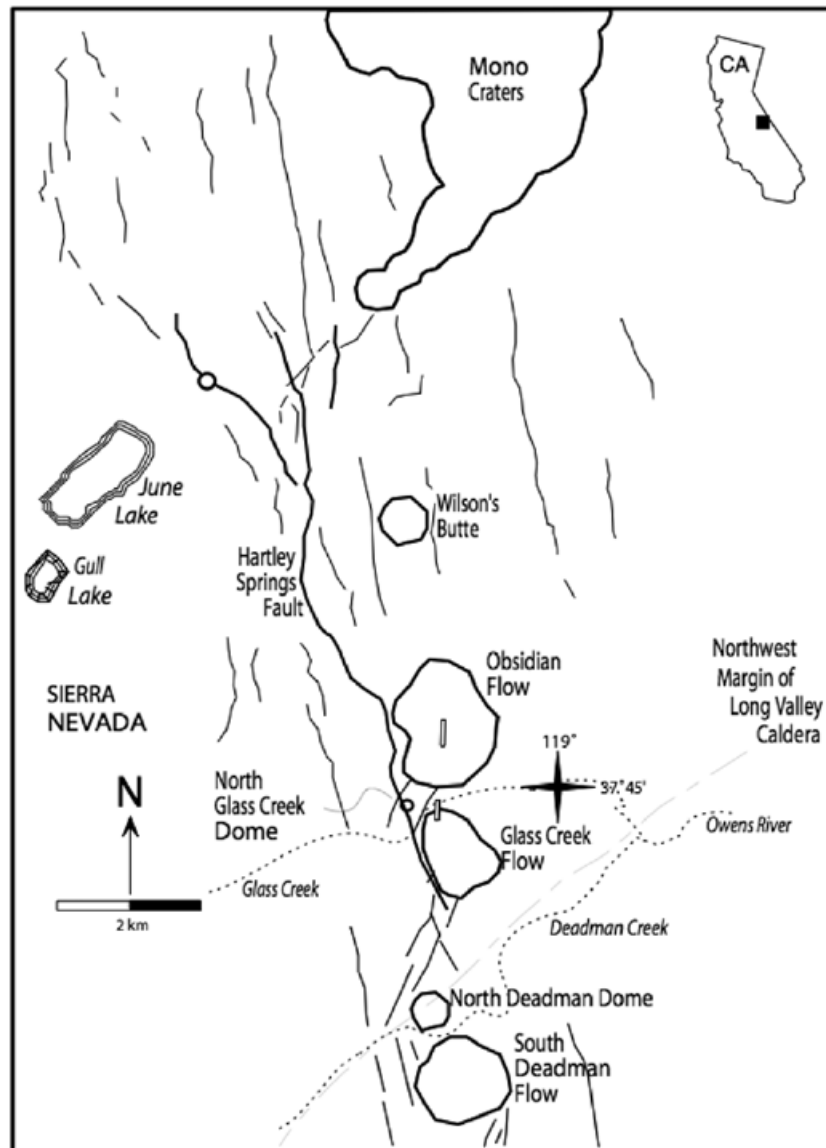

Fig. 6. Location of features in the southern Mono Basin/northern Long Valley caldera area (from Bursik *et al.*, 2003). Range-front faults are bold. Rectangular boxes on the Glass Creek and Obsidian Flows are map projections of Inyo Dike.

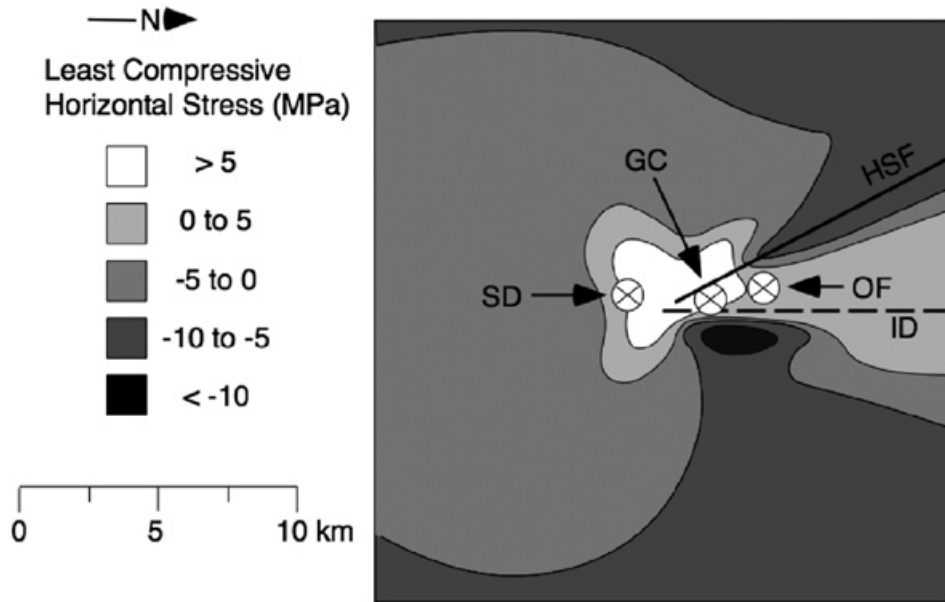

Fig. 7. Southern tip of the Hartley Springs Fault (HSF), showing the stress set up following injection of the Inyo Dike (ID), inducing oblique slip along the Hartley Springs Fault (HSF), and then formation of a low confining pressure region in the shallowest crust near the Obsidian Flow (OF), Glass Creek (GC) and South Deadman (SD) domes (from Bursik *et al.*, 2003).

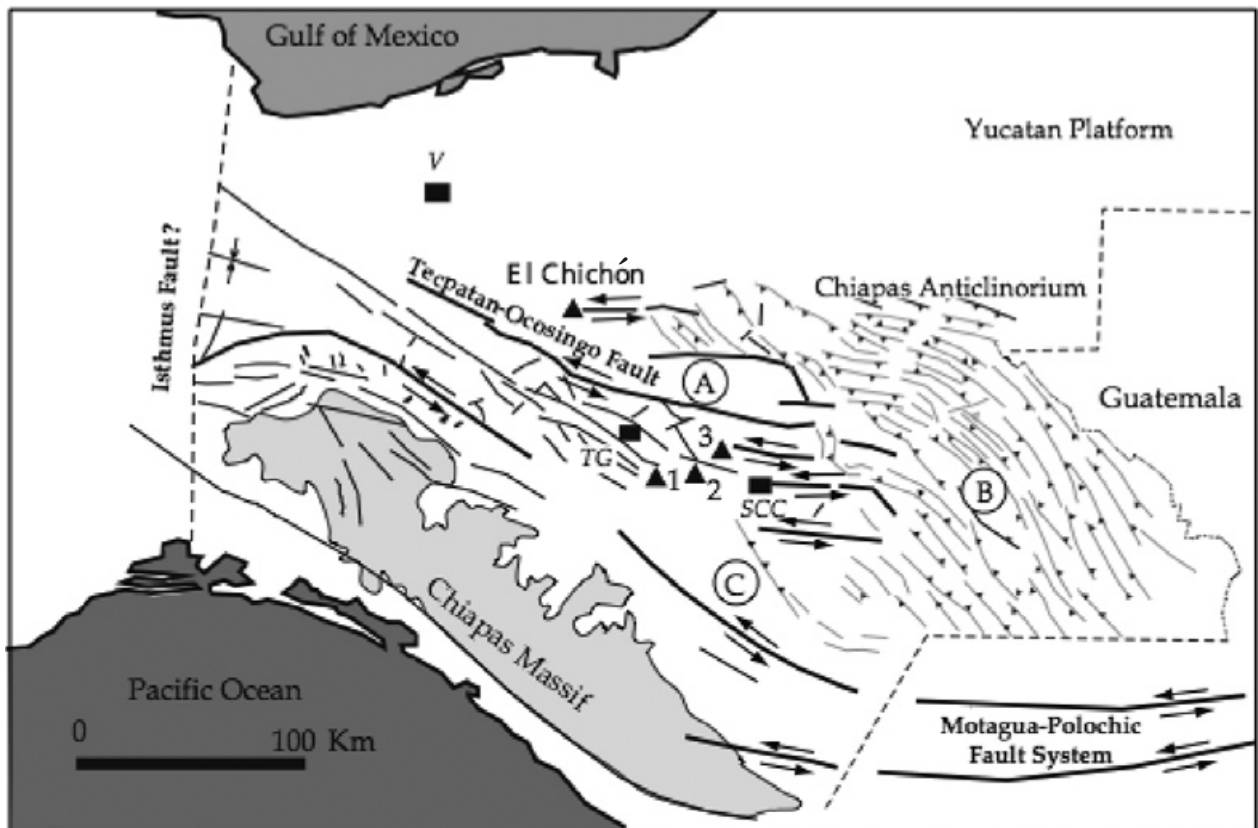

Fig. 8. Structural map of southern Mexico focussing on the constraining bend between the Strik-slip and Motagua-Polochick Fault Systems. The map shows: A, Strike-slip Fault Province; B, Reverse Fault Province; C, Homoclinal Province; V, Villahermosa; TG, Tuxtla Gutierrez; SCC, San Cristobal de las Casas. Volcanoes of the central Chiapanecan Arc: 1, Navenchauc; 2, Huitepec; 3, Tzontehuitz. Modified from Garcia-Palomo *et al.* (2004).

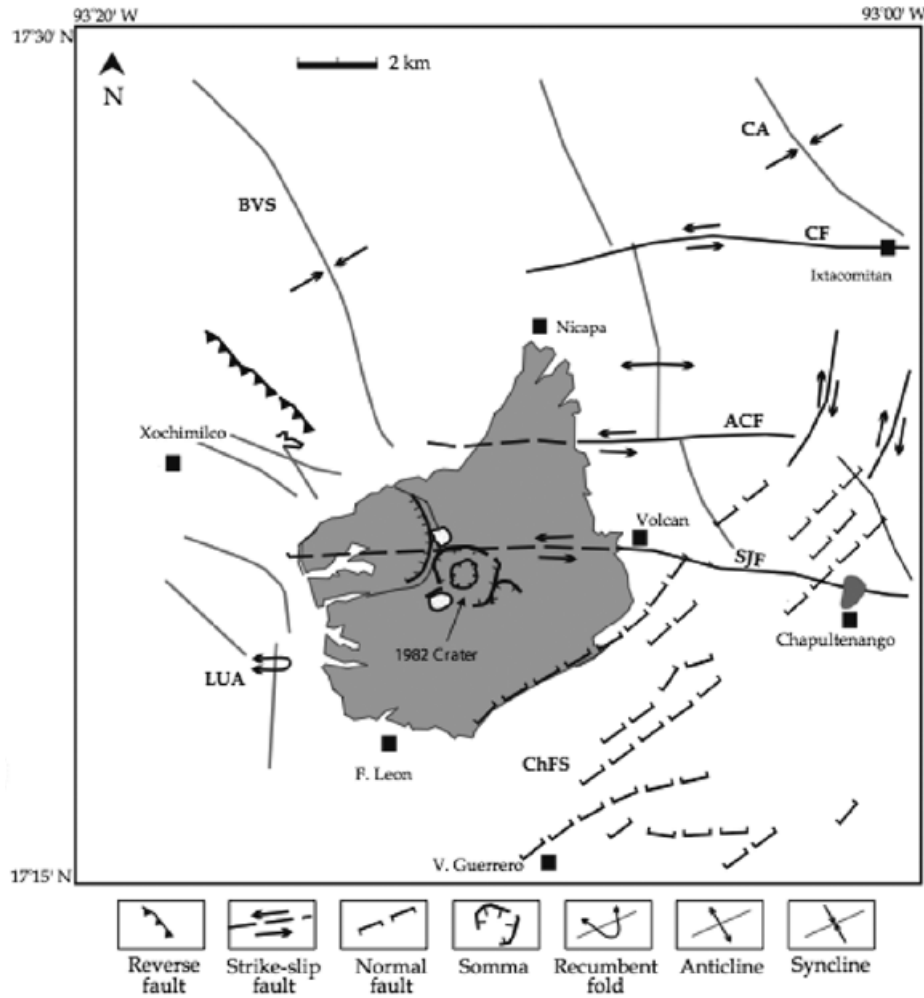

Fig. 9. Structural map of El Chichón volcano modified from Garcia-Paloma *et al.* (2004). For present purposes, the main features of interest are the position of the volcano relative to the San Juan Fault (SJF) and related, minor fault-tip structures.

caldera formation. What might be the nature of potential tectonic forcing that could account for the observation of only localized creation of calderas when an entire region would seem to be subjected to the same tectonic forcing?

Model

Long Valley caldera and the Mono-Inyo Craters are examples of development of magmatism in large-scale (~10-100 km) pull-aparts between oblique slip faults in an extensional environment. El Chichón is an example of the development of magmatism at a smaller scale (~1-10 km) in the tensional region at the tip of strike-slip faults in a transpressional environment. From what we know of these two examples, we can construct a general model for the accumulation, storage, rise and eruption of magma that is solely a response to tectonic stresses, without any appeal to

diapirism, buoyant rise or other factors intrinsic to magma (Fig. 11) (see also Vigneresse and Clemens, 2000). Linking these two might be the evolution of thrust-overthickened arc crust to extending crust as a plate boundary evolves to an intraplate setting. This evolution would of course involve the reactivation of compressional as extensional faults (Coney and Harms, 1984). Magma accumulates in pull aparts and other tensional structures along fault irregularities at depth in the arc setting (Fig. 11-1). The orientation of new accommodation space should be related to fault geometry as well as orientation of σ_3 . Along faults with a reverse motion component – predominantly in the arc environment, new accommodation space within the pull apart will tend to be oriented subvertically. Storage of the magma may occur within pull-aparts between separate fault segments at depth (Fig. 11-2). Transport of magma to the surface is expected to occur within fracture systems

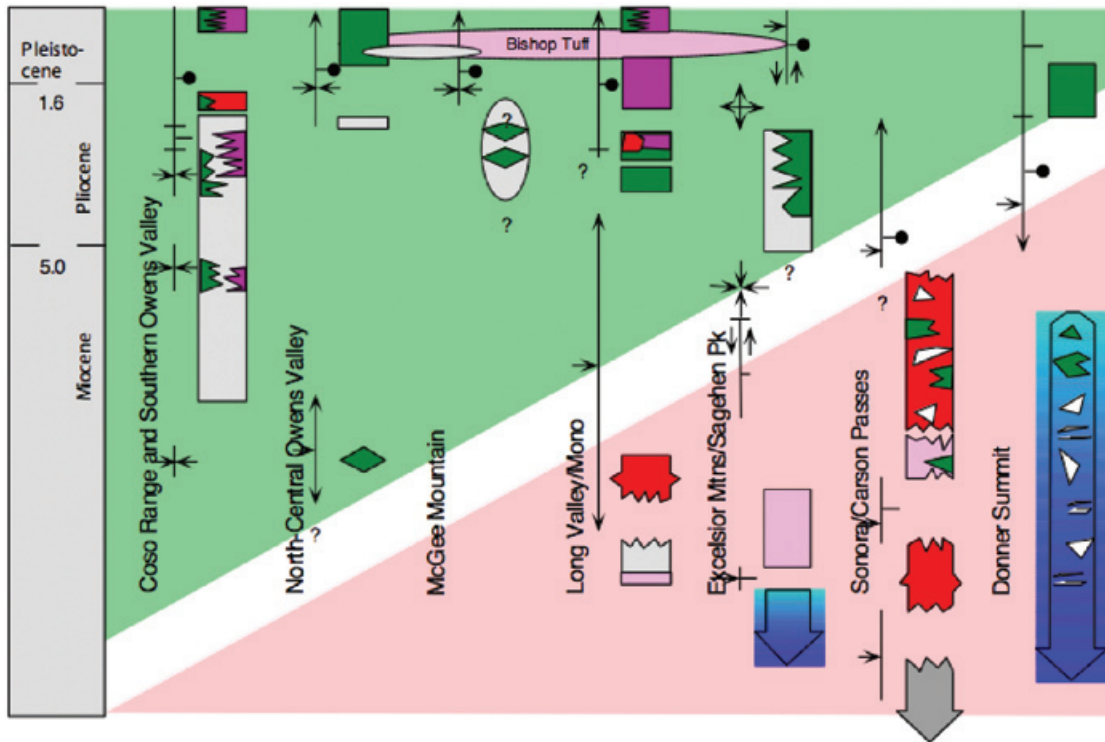

Fig. 10. Migration of tectonics and magmatic activity in the eastern Sierra Nevada region through time. Schematic diagram is oriented from South (left) to North (right) along the Sierran range front. Pink region is dominated by transpression and andesitic volcanism; green region by transension and bimodal volcanism. Green, basalt; purple, rhyolite-dacite; red, andesite; blue, unspecified. Tectonic setting is drawn as the corresponding structures would appear on a map. Contradictory features within the same work or as indicated by different authors have not been edited. Data sources can be found at NAVDAT (<http://navdat.geongrid.org>), and from works referenced therein.

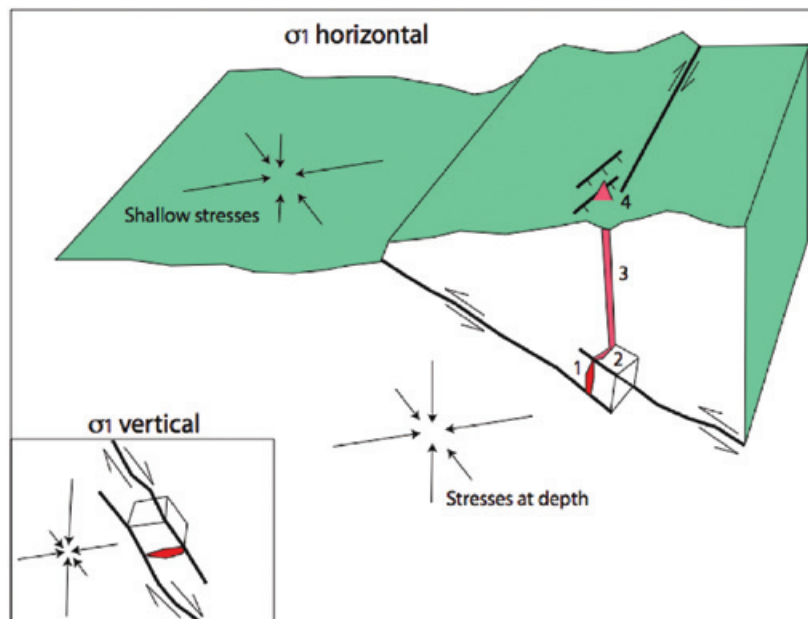

Fig. 11. Generalized model of interaction of tectonic elements and magmatic elements. The model is constructed in a transpressional setting, but would hold equally for a transtensional, with appropriate stress and strain rotations. The inset shows orientation of new magmatic intrusions if vertical stresses at depth are less than both horizontal components. 1, growth of pluton by sheeting; 2, accumulation and storage in a releasing or pull-apart region; 3, 4, migration of magma to surface and eruption at dynamically created areas of low confining pressure near fault tips or in pull-apart basins.

localized and oriented by the positions of low-confining pressure regions in the shallow crust, sometimes at least at the tips of strike-slip faults (Fig. 11-3). In regions of extension, along faults with a normal component having irregularities, releasing bends or pull-aparts at depth, new accommodation space will tend to be oriented subhorizontally (Fig. 11-inset). If large-scale pull-apart basins develop in the shallow crust, these may allow for the migration of large quantities of magma toward the shallow subsurface and surface in single caldera-forming events. Given the potential for evolution from compressing arc crust to extending intracontinental crust, the orientation of accommodation space at depth may evolve accordingly. Furthermore, it should be possible to globally link some measure of the rate of tectonism with some measure of the rate of volcanic activity.

Conclusions

We can summarize the observations and interpretations as follows. The spatial pattern of faulting indicates that Long Valley was focussed by a releasing bend in the range-front fault system. The temporal pattern of offset rates suggests that the zone of activity has migrated to the NW through time, and is now focussed at the Mono-Inyo Craters. The southern Mexican volcanic arc presents an example of the coexistence of regional compressional and transpressional structures with volcanoes. On an event basis, slip on regional structures creates opportunities for magma movement and eruption, by creation of regions of low confining pressure at fault tips (perhaps more common for stratovolcanoes) or within pull-apart basins (perhaps more common for ashflow calderas). Both kinematically and dynamically, volcanic activity may be completely dependent on tectonic factors for accumulation, storage and eruption of magma.

Acknowledgments. This work was supported in small part by numerous NASA and NSF grants over the years. (The first draft of the paper was written in 1989.) Most recently, NSF grant EAR0538227 was instrumental in the final development of the work. Jet Propulsion Laboratory is thanked for providing the imagery from the Large Format Camera (Bernard Molberg, PI). The editors and reviewers (V. H. Garduño and an anonymous reviewer) are thanked for their patience and helpfulness in improving the final product. The paper is dedicated to the memory of Armando García-Palomo.

Bibliography

Achauer, U., L. Greene, J. R. Evans and H. M. Iyer, 1986. Nature of the magma chamber underlying the mono craters area, eastern California, as determined from teleseismic travel time residuals. *Journal of*

Geophysical Research, 91, B14, 13,873–13,891.

Bailey, R. A., G. B. Dalrymple and M. A. Lanphere, 1976. Volcanism, structure, and geochronology of long valley caldera, mono county, california. *Journal of Geophysical Research*, 81, 5, 725–744.

Bateman, P. C., 1965. Geology and tungsten mineralization of the bishop district, california. Technical Report 1044-9612.

Bartolome, C., Ma. L. Bautista, P. Bautista and R. S. Stein, 1996. Edito Barcelona, S. Raymundo S. Punongbayan, Eduardo P. Laguerta, Ariel R. Rasdas, Gemme Ambubuyog, and Erlinda Q. Amin. Relationship of regional and local structures to mount Pinatubo activity. In Christopher G. Newhall and Raymundo S. Punongbayan, editors, Fire and Mud, pages 351–370. Philippine Institute of Volcanology and Seismology and University of Washington Press, Quezon City, Seattle and London.

Bursik, M., C. Renshaw, J. McCalpin and M. Berry, 2003. A volcanotectonic cascade: Activation of range front faulting and eruptions by dike intrusion, Mono Basin-Long Valley Caldera, California. *Journal of Geophysical Research*, 108, 2393.

Bursik, M. I. and K. E. Sieh, 1989. Range front faulting and volcanism in the Mono Basin, eastern California. *Journal of Geophysical Research*, 94, 15, 587–15,609.

Cambray, F. W., T. A. Vogel and Jr. J. G. Mills, 1995. Origin of compositional heterogeneities in tuffs of the Timber Mountain Group: the relationship between magma batches and magma transfer and emplacement in an extensional environment. *Journal of Geophysical Research*, 100, 15793–15805.

Carle, S., F., 1988. Three dimensional gravity modeling of the geologic structure of long valley caldera. *Journal of Geophysical Research*, 93, 11, 13,237–13,250.

Cichanski, M., 2000. Low-angle, range-flank faults in the Panamint, Inyo, and Slate ranges, California: implications for recent tectonics of the Death Valley region. *Geological Society of America Bulletin*, 112, 871–883.

Cole, J. W., D. M. Milner and K. D. Spinks, 2005. Calderas and caldera structures: a review. *Earth Science Reviews*, 69, 1–26.

Coleman, D. S., W. Gray and A. F. Glazner, 2004. Rethinking the emplacement and evolution of zoned

- plutons: geochologic evidence for incremental assembly of the Tuolumne Intrusive Suite, California. *Geology*, 32, 433 – 436.
- Coney, P. J. and T. A. Harms, 1984. Cordilleran metamorphic core complexes; Cenozoic extensional relics of Mesozoic compression. *Geology*, 12, 550 – 554.
- García-Palomo, A., J. L. Macías and J. M. Espíndola, 2004. Strike-slip faults and K-alkaline volcanism at El Chichón volcano, southeastern Mexico. *Journal of Volcanology and Geothermal Research*, 136, 247 – 268. doi:10.1016/j.jvolgeores.2004.04.001.
- Gilbert, C. M., M. N. Christensen, Y. Al-Rawi, and K. R. Lajoie, 1968. Structural and volcanic history of Mono basin, California-Nevada. In Robert R. Coats, editor, *Studies in volcanology-A memoir in honor of Howel Williams*, pages 275–329. Geological Society of America Memoir, 116.
- Gilbert, C. M., 1941. Late tertiary geology southeast of mono lake, California. *Geological Society of America Bulletin*, 52, 6, 781–815.
- Guzmán-Speziale, M. and J. J. Meneses-Rocha, 2000. The North American-Caribbean plate boundary west of the Motagua-Polochic fault system: a fault jog in Southeastern Mexico. *Journal of South American Earth Sciences*, 13, 459–468.
- Guzmán-Speziale, M., W. D. Pennington and T. Matumoto, 1989. The triple junction of the North America, Cocos and Caribbean plate boundary zone. *Tectonics*.
- Hildreth, E. W. and G. A. Mahood, 1986. Ring fracture eruption of the bishop tuff. *Geological Society of America Bulletin*, 97, 4, 396–403.
- Hill, D. P., 2006. Unrest in Long Valley Caldera, California, 1978–2004. In C. Troise, G. de Natale, and C.R.J. Kilburn, editors, *Mechanisms of Activity and Unrest at Large Calderas*, volume 269 of Special Publications, pages 1–24. Geological Society of London.
- Hill, D. P., F. Pollitz and C. NewHall, 2002. Earthquake-volcano interactions. *Physics Today*, 55, 41–47.
- Huber, N. K., 1981. Amount and timing of late Cenozoic uplift and tilt of the central Sierra Nevada, California – evidence from the upper San Joaquin River Basin. U. S. *Geological Survey Professional Paper*, 1197, 1–28.
- Huber, N. K. and C. Dean Rinehart, 1965. Geologic map of the devils postpile quadrangle, Sierra Nevada, California. Technical report.
- Hutton, D. H. W., 1992. Granite sheeted complexes: evidence for the dyking ascent mechanism. *Transactions of the Royal Society of Edinburgh*, 83, 377 – 382.
- Hutton, D. H. W. and R. J. Reavy, 1992. Strike-slip tectonics and granite petrogenesis. *Tectonics*, 11, 960 – 967.
- Krauskopf, K. B. and P. C. Bateman, 1977. Geologic map of the glass mountain quadrangle, Mono County, California, and mineral county, Nevada. Technical report.
- Lagmay, A. M. F., A. M. P. Tengonciang and H. S. Uy, 2005. Structural setting of the Bicol Basin and kinematic analysis of fractures on Mayon Volcano, Philippines. *Journal of Volcanology and Geothermal Research*, 144, 23 – 36, 2005.
- Lagmay, A. M. F., B. van Wyk de Vries, N. Kerle and D. M. Pyle, 2000. Volcano instability induced by strike-slip faulting. *Bulletin of Volcanology*, 62, 331 – 346.
- Lajoie, K. R., 1968. Late Quaternary stratigraphy and geologic history of Mono Basin, eastern California. Ph.d., University of California, Berkley.
- Linde, A. T. and I. Selwyn Sacks, 1998. Triggering of volcanic eruptions. *Nature*, 395, 6705, 888–890.
- Lipman, P. W., H. J. Prostka and R. L. Christiansen, 1972. Cenozoic volcanism and plate-tectonic evolution of the Western United States. I. Early and Middle Cenozoic. *Philosophical Transactions of the Royal Society of London A*, 271, 271 – 248.
- Lipman, P. W., 1997. Subsidence of ash-flow calderas: relation to caldera size and magma-chamber geometry. *Bulletin of Volcanology*, 59, 198–218.
- Malfait, B. T. and M. G. Dinkelman, 1972. Circum-Caribbean tectonic and igneous activity and the evolution of the Caribbean Plate. *Geological Society of America Bulletin*, 83, 251 – 272.
- Manga, M. and E. Brodsky, 2006. Seismic triggering of eruptions in the far field: volcanoes and geysers. *Annual Review of Earth and Planetary Sciences*, 34, 263–291.

- Metz, J. M. and G. A. Mahood, 1985. Precursors to the bishop tuff eruption; glass mountain, Long Valley, California. *Journal of Geophysical Research*, 90, 13, 11,121–11,126.
- Mora, J. C., M. C. Jaimes-Viera, V. H. Garduño Monroy, P. W. Layer, V. Pompa-Mera and M. L. Godinez, 2007. Geology and geochemistry of the Chiapanecan Volcanic Arc (Central Area), Chiapas, Mexico. *Journal of Volcanology and Geothermal Research*, 162, 43–72.
- Nakamura, K., K. H. Jacob and J. N. Davies, 1977. Volcanoes as possible indicators of tectonic stress orientation – Aleutians and Alaska. *Pure and Applied Geophysics*, 115, 1–2, 87–112.
- Parsons, T. and G. A. Thompson, 1991. The role of magma overpressure in suppressing earthquakes and topography: Worldwide examples. *Science*, 253, 1399–1402.
- Putnam, W. C., 1962. Late cenozoic geology of McGee mountain, Mono County, California. *University of California Publications in Geological Sciences*, 40, 3, 181–207.
- Rinehart, D. D. and D. C. Ross, 1964. Geology and mineral deposits of the mount morrison quadrangle, sierra nevada, california. Technical report.
- Sieh, K. and D. Natawidjaja, 2000. Neotectonics of the Sumatran fault, Indonesia. *Journal of Geophysical Research*, 105, 28,295 – 28,326.
- Slemmons, D. B., D. Van Wormer, E. J. Bell and M. L. Silberman. Recent crustal movements in the Sierra Nevada – Walker Lane region of California – Nevada: part I, rate and style of deformation. *Tectonophysics*, 52, 561ff
- Smith, R. L. and R. A. Bailey, 1968. Resurgent cauldrons. *Geological Society of America Memoir*, 116, 613 – 662.
- Spinks, K. D., V. Acocella, J. W. Cole and K. N. Bassetta. Structural control of volcanism and caldera development in the transtensional Taupo Volcanic Zone, New Zealand. *Journal of Volcanology and Geothermal Research*, 144, 7–22, 2005.
- Tilling, R., M. Rubin, H. Sigurdsson, S. Carey, W. Duffield, and W. Rose. Holocene eruptive activity of El Chichon volcano, Chiapas, Mexico. *Science*, 224, 747–749, 1984.
- Vegas, N., A. Aranguren and J. M. Tubia, 2001. Granites built by sheeting in a fault stepover (the Sanabria Massifs, Variscan Orogen, NW Spain). *Terra Nova*, 13, 180–187.
- Vignerresse, J. L. and J. D. Clemens, 2000. Granitic magma ascent and emplacement: neither diapirism nor neutral buoyancy. *Geological Society of London Special Publications*, 174, 1 – 19. doi:10.1144/GSL.SP.1999.174.01.01.
- Walter, T. R., 2007. How a tectonic earthquake may wake up volcanoes: stress transfer during the 1996 earthquake–eruption sequence at the Karymsky Volcanic Group, Kamchatka. *Earth and Planetary Science Letters*, 264, 347 – 359.
- Wernicke, B., G. J. Axen and J. Kent Snow, 1988. Basin and Range extensional tectonics at the latitude of Las Vegas, Nevada. *Geological Society of America Bulletin*, 100, 738 – 1757.
- Wesnousky, S. G. and C. H. Jones, 1994. Oblique slip, slip partitioning, spatial and temporal changes in the regional stress field, and the relative strength of active faults in the Basin and Range, western United States. *Geology*, 22, 1031–1034.

M. Bursik

Department of Geology, State University of New York at Buffalo, New York 14260 USA

**Corresponding author: mib@buffalo.edu*