

## The Mexican Meteor Network: A Preliminary Proposal

Guadalupe Cordero-Tercero\*, Fernando Velázquez-Villegas, Carlos Francisco Vázquez-Hernández, José Luis Ramírez-Cruz, Alejandro Arévalo-Vieyra, Asahel Mendoza-San-Agustín and Fernando Camacho-Martínez

Received: June 10, 2015; accepted: July 29, 2015; published on line: December 31, 2015

### Resumen

El estudio de la entrada a la atmósfera terrestre de material asteroidal y cometario tiene importancia científica y social. La observación y estudio del impacto de meteoroides con nuestro planeta es una forma de estudiar geofísica y geología planetarias sin naves espaciales. En este artículo se muestran los avances de la instalación de la Red Mexicana de Meteoros (Citlalin Tlamina) cuyo objetivo, a mediano y largo plazo, es poder cubrir todo el territorio nacional con estaciones que nos permitan registrar la entrada de meteoroides a la atmósfera terrestre. Con esto se busca: a) estudiar en detalle la interacción meteoroides-atmósfera, b) determinar propiedades físicas de los impactores; c) analizar flujos y desviaciones del radiante de las lluvias de estrellas conocidas, d) encontrar o ratificar nuevas lluvias de estrellas; e) recuperar y estudiar meteoritas, f) estudiar la interacción de la onda de choque con el suelo mediante el análisis de sismogramas; g) informar en tiempo real (o casi) a las personas la ocurrencia de bólidos y fragmentación de meteoroides en la atmósfera, evitando el miedo hacia este tipo de fenómenos y servir de apoyo a Protección Civil y h) encontrar áreas de oportunidad que puedan hacer uso de las imágenes captadas por las cámaras (meteorología, migración de aves, etc.). En este trabajo se muestra el prototipo de la base que albergará las cámaras y cuyo propósito es protegerlas del medio ambiente, evitar la condensación dentro de los contenedores de las cámaras y mantenerlas a una temperatura inferior a los 25 °C.v.

Palabras clave: meteor, meteorita, meteoroides, cuerpos pequeños, red de cámaras, Protección Civil.

### Abstract

The study of asteroidal and cometary material entering into Earth's atmosphere has scientific and social importance. The observation and study of the impact of meteoroids with our planet is a way of studying geophysics and planetary geology without spaceships. This article describes the progress of the installation of the Mexican Meteor Network (Citlalin Tlamina). At medium and long term, the aim of this network is to cover the entire national territory with stations that allow us to record the entry of meteoroids into Earth's atmosphere. This seeks to: a) study the meteoroid-atmosphere interaction, b) determine impactor's physical properties; c) analyze flows and Radiant deviations of known meteor showers, d) find or ratify new meteor showers; e) recover and study meteorites, f) study the interaction of the shock wave with the ground by analyzing seismograms; g) report people in real time (or near) the occurrence of fireballs and fragmentation of meteoroids in the atmosphere, avoiding the fear of this phenomenon and provide support for Civil Protection, h) find areas of opportunity that can use the images captured by the cameras (weather, bird migration, etc.). In this paper, it is shown the prototype of the base to house the cameras whose purpose is to protect them from the environment, prevent condensation within the container and keep the cameras below 25 °C.

Key words: meteor, meteorite, meteoroid, small bodies, video network, Civil Protection.

---

G. Cordero-Tercero\*  
Departamento de Ciencias Espaciales  
Instituto de Geofísica  
Universidad Nacional Autónoma de México  
Circuito de la Investigación Científica s/n  
Ciudad Universitaria  
Delegación Coyoacán, 04510  
México D.F. México  
\*Corresponding autor: [gcordero@geofisica.unam.mx](mailto:gcordero@geofisica.unam.mx)

F. Velázquez-Villegas  
C. F. Vázquez-Hernández  
J. L. Ramírez-Cruz  
A. Arévalo-Vieyra,  
A. Mendoza-San-Agustín  
F. Camacho-Martínez  
Centro de Ingeniería Avanzada  
Universidad Nacional Autónoma de México  
Circuito de la Investigación Científica s/n  
Ciudad Universitaria  
Delegación Coyoacán, 04510  
México D.F. México

## Introduction

When a comet, asteroid or meteoroid collides with a planet several things can happen depending on the mass, velocity and composition of the object, if the planet or moon has an atmosphere or not, and the angle of impact. In airless bodies, like Mercury or the Moon, all objects that strike their surfaces produce impact craters whose sizes range from centimeters to hundreds and even thousands of kilometers across. In bodies with atmosphere, the encounter with a meteoroid or small body (asteroid or comet) can produce impact craters, meteorites, meteors and fragmentation of the original body, depending on the kinetic energy of the object.

Meteors, also called shooting stars, are bright trails in the sky produced by the heating and incandescence of micrometeorites and meteoroids in the terrestrial atmosphere. A meteoroid is asteroidal or cometary material whose size is between 2 mm and 1-10 meters long (Ceplecha *et al.*, 1998; Rubin and Grossman, 2010). These objects generally evaporate at heights between 80 and 120 km (Glass, 1982). Objects of less than 2 mm are known as micrometeorites (Hutchinson, 2004). If the brightness of the meteor outshines the planet Venus (magnitude - 4), the phenomenon is called bolide or fireball (Trigo-Rodríguez *et al.*, 2005). Objects between 0.05 mm and 20 cm in diameter produce meteors (Ceplecha *et al.*, 1998) while objects larger than 1 m usually produce fireballs whose shine last from a second up to 5-10 seconds (Shumilov *et al.*, 2003; Trigo-Rodríguez *et al.*, 2005).

If a meteoroid, or a fragment of it, survives atmospheric ablation and can be recovered on the ground, that piece is called a meteorite. Meteorites can be classified according to their materials or according to their origin. Following the first criterion, they fall into one of three types: iron (iron-nickel), stone (silicates) and stony-iron (iron, nickel and silicates) (Weisber, 2006). According to their origin, meteorites are classified into two groups; differentiated and undifferentiated meteorites. Each one of these groups has subdivisions. Undifferentiated meteorites can be chondrites (which in turn are divided into 5 types) and primitive achondrites. Differentiated meteorites are divided into achondrites, iron meteorites and stony-iron meteorites (Cervantes, 2009). The study of meteorites has been and will be very important for understanding the physical and chemical conditions that existed inside the primitive solar nebula, to estimate the age of formation of the solar system and to model the

interiors of planets and moons (Hutchinson, 2004; Taylor 2001; Pater and Lissauer, 2001).

The impact velocity of a meteoroid or a small body with another planetary body depends on the escape velocity of the latter, its heliocentric orbital velocity and velocity of the impactor at the heliocentric distance of the impacted body. For Earth, the minimum speed of impact is the escape velocity 11.2 km / s, and the maximum is 72.8 km / s. When meteoroids and asteroids up to a few tens of meters in diameter interact with the Earth's atmosphere, they slow down as they go into more dense layers. The friction between a meteoroid (or asteroid or comet) and air, heat the object up to the material is ablated. The aerodynamic pressure of the atmosphere on small asteroids or meteoroids can be greater or equal to their internal strength; in this case the object fragment suddenly in the atmosphere producing shock waves.

The fragmentation of the object is not immediate; the pressure wave must be transmitted into the body. It occurs fairly quickly because the propagation velocity of such waves is between 2930 m s<sup>-1</sup> and 5110 m s<sup>-1</sup>, even 6260 m s<sup>-1</sup> in iron meteorites (Flynn *et al.*, 1999). At first, the fragments have the same shock wave, but as they separate laterally, more space is among them until each fragment acquires its own shock wave. When this sudden separation occurs it is said that the object explodes (Melosh, 1989; Hills and Goda, 1993).

When the object that is broken is tens of meters long, its fragments may hit the ground with enough kinetic energy to create several impact craters (Passey and Melosh, 1980). On our planet there are around a dozen of such structures, which are known as fields of craters.

During the XX and XXI centuries, a series of events showed the importance of collisions between planets and minor planets (comets and asteroids). On Earth, we can mention three interesting events: Tunguska, Curuça and Chelyabinsk. On the morning of June 30, 1908, an object of between 50 and 100 m suddenly broken at a height of 5-10 km with an energy of 10-50 Mt TNT (Svetsov and Shuvalov, 2008). The blast completely destroyed the material so none impact crater was formed, but the shock wave produced during the fragmentation had the enough energy to break down trees inside an area of 2150 km<sup>2</sup> (Farinella *et al.*, 2001). That same shock wave produced an earthquake of magnitude 4.7 (Ben-Menahem, 1975). A similar phenomenon, the Curuça event,

occurred in the Brazilian Amazon on August 13, 1930 (Bailey *et al.*, 1995; Reza *et al.*, 2004). This event did not create impact craters, at least not recognizable currently but the energy of the explosion was much more modest than Tunguska's, probably some few kilotons of TNT. It occurred in a sparsely populated area around the Curuça river, near the border between Brazil and Peru. At this point, it is important to emphasize that this event is known thanks to a catholic missionary who arrived at the scene a few days after, and made a report that was published in the Vatican newspaper in 1931 (Cordero and Poveda, 2011). A more recent event occurred on 15 February, 2013 on Chelyabinsk region, Russia. It is estimated that a rocky (chondritic) asteroid of about 19.8 m in diameter with an initial kinetic energy between 470 and 590 kT entered into the Earth's atmosphere where it suffered a couple of fragmentations above 27 km altitude. The shock wave, produced by the explosion of this asteroid in the atmosphere, caused cracks in walls and broken windows. Shattered glasses hurt more than one thousand and five hundred persons (Popova *et al.*, 2013).

On February 10, 2010, near the border between Puebla and Hidalgo States, Mexico, people heard an explosion that alarmed the population. Some kilometers away, some persons observed a bolide. This event may have been the sudden fragmentation of an object in the atmosphere. It is estimated that the explosion could have released an energy of a few kilotons. While studying this event we realized the social value of alerting the population about such phenomena because it cause great fear and can represent many hours of lost work for members of Civil Protection (Cordero *et al.*, 2011). On February 22, 2011 another fireball was observed in Mexico, this time near the border between Aguascalientes and Zacatecas. This last event reaffirmed the need for a continuous monitoring system of meteors and fireballs.

There are several ways to detect the entry of meteoroids and small bodies in the Earth's atmosphere: naked eye, photographs, videos, radar, lidar and infrasound. Putting aside the observations with the naked eye, which is obviously the oldest technique (Yang, *et al.*, 2005), systematic observations of meteors using cameras have been conducted since the 1950s. The first observations were made in Czechoslovakia, and then by three other camera networks in Europe, USA and Canada (Oberst, 1998). The next step was the use of networks of video cameras that allow monitoring the sky in a more systematic

way, among such networks are the European meteor video observation network (EDMON) and the IMO Video Meteor Network that include networks in several European countries. There are also the Spanish Meteor Network (SPMN) (Trigo-Rodríguez *et al.*, 2004) and the Fireball Recovery and Interplanetary Observation Network (Fripon), this one is a 100 camera network established on France. In America there is the North American All-Sky Camera Network with stations in Canada, United States of America and one station in Mexico (Hermosillo).

Currently, we are working to have the Mexican Meteor Network whose informal name is Citlalin Tlamina (« meteor » in nahuatl language). With this network, we want to a) Determine values of meteoroid's parameters to be used in numerical modeling of the dynamics of these objects through Earth's atmosphere, b) determine the conditions under which seismic waves are created due to the shock wave that is produced by the fragmentation of a meteoroid in the atmosphere; c) understand the coupling of atmospheric shock wave with the ground, and the information that can be obtained about height and energy of the explosion, d) know the region meteoroids come from (main belt asteroids, Earth's neighborhood, etc.); e) extrapolate meteoroid trajectory to retrieve meteorites, f) study meteorites, g) study known and probable meteor showers ; h) communicate the entry of large meteoroids to Civil Protection to help them to manage the situation with people and retrieving of meteorites or space debris, and i) find areas of opportunity, looking for researches interested in our data to study weather, complex phenomena, etc.

### Problem Statement

Buil (1994) gives a series of recommendations to choose the most suitable photographic equipment and lenses to observe meteors. After looking for some options, we decided to use the equipment that José María Madiedo-Gil and Josep Trigo-Rodríguez recommended to us. They work in the Spanish Meteor Network (SPMN) and they have used several types of cameras and lenses to observe meteors since 2004 (Trigo *et al.*, 2004). So to set up the Mexican Meteor Network, we acquired WAT-902 H2 Ultimate (EIA) cameras and lenses with an image size of 1/3 "and a focal length of 0.3 to 8 mm because this equipment has been very useful to observe meteors due to its efficiency (Figure 1) (Madiedo and Trigo, 2008; Madiedo *et al.*, 2009; Madiedo *et al.*, 2010; Madiedo *et al.*, 2013). Once we have this equipment, the next action was to design a base to protect the

cameras. For this purpose, a monitoring station was designed with five cameras to the horizon in 360° and one camera towards the zenith. We chose to form a station with 6 cameras because, during previous observation campaigns, we realized that 4 cameras were not enough to cover the entire free sky. According to our observations, we needed 6 cameras to get it. The fields of vision of these 6 cameras overlap a bit, but this, far from being a problem is an advantage as it is likely that a meteor can be seen by two or more cameras at each station. Conditions of high temperature and humidity were considered in our design. The aim was then design the mechanical interface of the monitoring station used to observe meteors and fireballs entering the Earth's atmosphere.

The requirements for the interface were: a) To protect cameras from the environment, b) to allow free vision, c) to keep the operation temperature of the cameras (about 25°C), d) to keep the relative humidity and temperature around the cameras in a specific range to avoid condensation (75% of relative humidity, a temperature of 25°C), e) to allow elevation of the cameras between 40° and 50°, f) low cost, and g) low maintenance. At first, it was thought to use the cameras to observe meteors at night, but in the near future the base will be modify to perform daytime observations. No other factors were considered, but more constraints can be regarded according to how the system works.

## Methodology

We generated some conceptual solutions for each requirement. After evaluating, the following solutions were selected because of their simplicity, low cost and easy manufacture:

In order to protect the cameras from the environment, acrylic cages were used, because it is a low cost and simple manufacture material

(Figure 2). Another solution, perhaps more aesthetic, was to use a dome made of acrylic, but it was about 3 times more expensive and more difficult to solve the problem of condensation inside.

To have an adequate view, the front face of each cage was made of glass.

In order to keep a functional temperature for the cameras, they were attached to an aluminum plate that dissipates heat. Besides, this plate is cooled by a fan that produces forced convection (Figure 3). Also we implemented over the cages a cover of reflective material to reduce heating because of Sun light. The first option was to implement an environmental conditioning system but, once again, the cost was the main issue.

Silica gel was used to absorb humidity and to avoid condensation inside cages. The mass quantity of silica that is necessary to absorb humidity inside the cage is 15 mg. To prevent ingress of water vapor, joints between the acrylic cages and glass were sealed with silicone, and joints between acrylic cages and their metal base were sealed placing a plastic seal and silicone. We thought to use an electric air dryer system but it was more complicated for maintenance.

We implemented round rails and hinges to allow camera elevation (Figure 4).

To manage the video signal from the cameras, we use a frame grabber of EPIX (PIXCI SV5). Each camera is connected to a single PC to prevent interference of signals from two or more cameras.

To get data, we use UFOCapture software which allows further adjustments than the software attached to PIXCI SV5 grabbers. At the moment, all data is stored in internal



**Figure 1.** Camera and lens used in the Mexican Meteor Network.

disks of each PC, then this information is down into an external disk. After that, videos are classified (clouds, rain, lightning, insects, etc.) or deleted (if they lack of scientific interest). We only analyzed videos of meteors.

**First design and preliminary results**

The monitoring station designed has: a) Individual compartments or cages for each camera, b) humidity cages that contain silica gel, c) individual and independent elevation of each horizontal camera, and d) cooling system

(Figure 5). This arrangement allows to move and provide maintenance of each camera independently (Figure 6).

**First meteor shower report.**

The eta aquarids is an annual meteor shower due to the entry of Halley comet particles into Earth’s atmosphere. These particles ablate totally in the atmosphere at the same time they produce easily detectable meteors. The maximum flow of the fall of these particles occurred this year on the morning of May 6<sup>th</sup>.

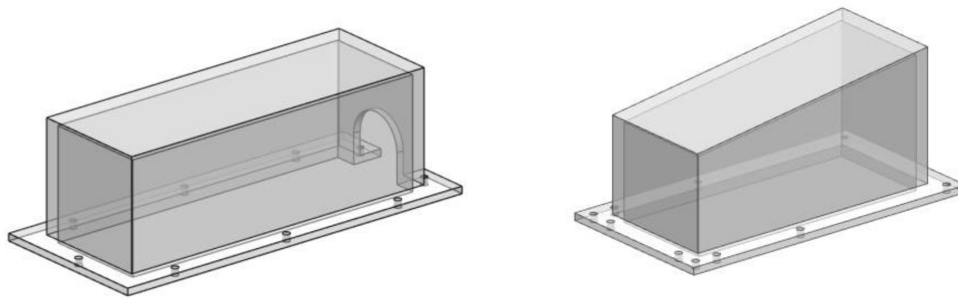

**Figure 2.** Cages to protect cameras.

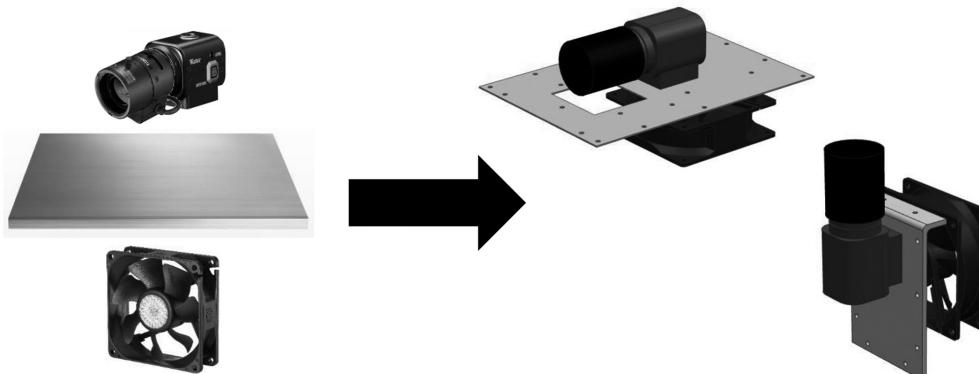

**Figure 3.** Cameras Platform.

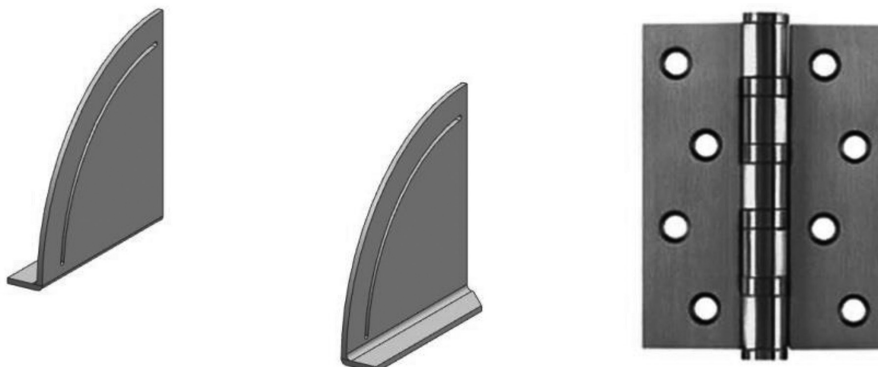

**Figure 4.** Round rails and hinges.

Taking the advantage of this event, we used the instrument described above. We put the first station of the Mexican Meteor Network (Citlalin Tlamina) on the roof of the Institute of Geophysics at UNAM (Universidad Nacional Autónoma de México) in Mexico City to observe these meteors on the night of May 6<sup>th</sup> (Fig. 7). Due to weather conditions, we recorded

only two meteors, one of them is shown in the Figure 8. To obtain this figure, we use the Maxim DL software. Since that day, we have made a series of night observations. This has allowed us to realize about the strengths and weaknesses of the design, and it has shown us the direction of future work.

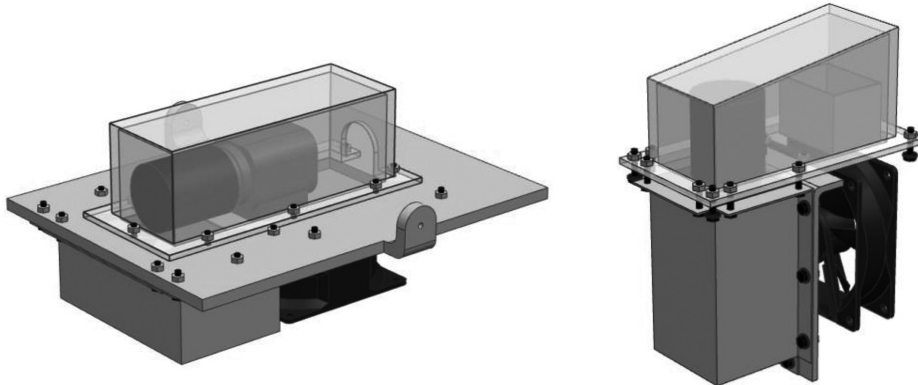

**Figure 5.** Final arrangement for the vertical and horizontal cameras.

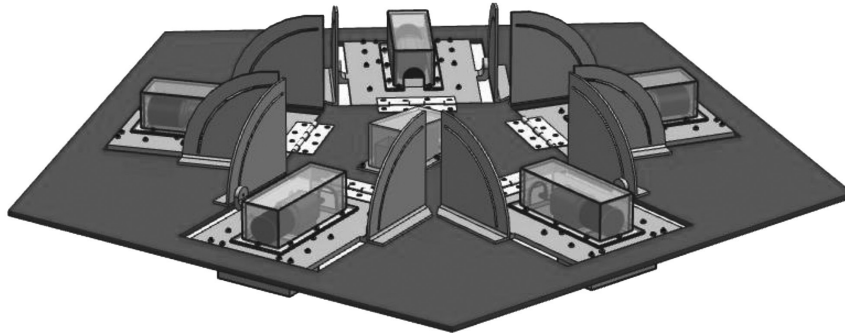

**Figure 6.** Final design and layout of cameras.

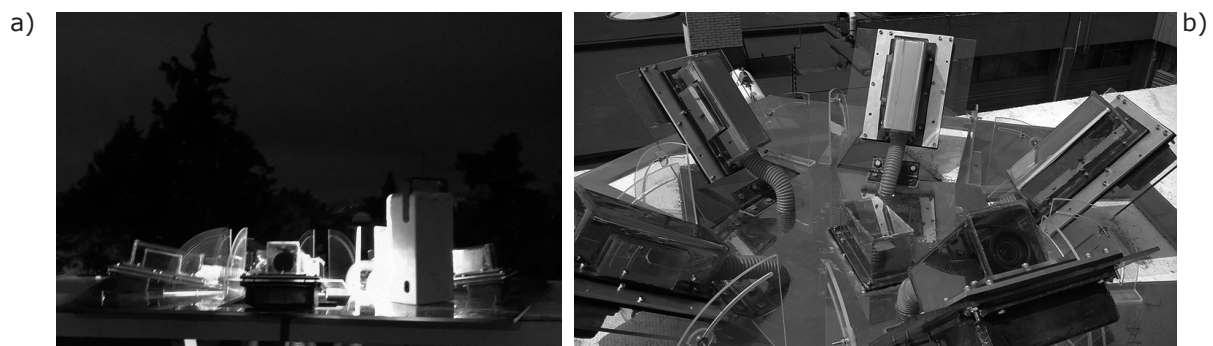

**Figure 7.** a) View of the first station of Citlalin Tlamina the night of May 6, 2015, b) approach to the base.

**Figure 8.** Image of an eta aquarids meteor (trace indicated by the white arrow).



### Conclusions.

The monitoring station design protects the cameras from environment, ensuring their correct operation and allowing the observation of meteors and fireballs produced by meteoroids and small asteroids that enter into the Earth's atmosphere. The covers of reflective material used over the acrylic cages improve their durability despite the sun light. The fans and the silica gel maintain the environment inside the cages in adequate conditions for the cameras performance. It should be mentioned that our main constraint was cost and, as a consequence of that, the station needs to be monitored as regularly as possible in order to decide when to change the acrylic cages or to add or replace the silica gel.

The cost of the monitoring station is very low, because of the low cost materials used and its simple configuration.

The monitoring stations could be located almost anywhere due to cameras are completely isolated from the external environment, avoiding inclement weather inside the cages.

The design is being tested since May 6, 2015, day when we observed the eta Aquarids. On this occasion only two meteors were recorded because bad weather conditions (very cloudy sky). In the coming months, the current base will be improved to solve some problems and a new base will be design based on experience.

### Acknowledgments

All authors thank anonymous reviewers for their helpful and thoughtful comments and suggestions. One of the authors, G. Cordero is grateful to Josep Trigo-Rodriguez and Jose Maria Madiedo-Gil for their advice on the choice of camera equipment and lenses, and to Diego González, Said González, Sonia Coenejo and Mar Almazán for their help in various aspects of this Project. This work is being supported by CONACYT (Project 167750: Estudio de la dinámica de meteoroides a través de la atmósfera terrestre y recuperación de meteoritos), and partially by the projet I887A from the Agencia Espacial Mexicana.

### References

- Ben-Menahem A., 1975, Source Parameters of the Siberian Explosion of June 30, 1908, from Analysis and Synthesis of Seismic Signals at Four Stations. *Phys. Earth Planet. Int.*, 11, 1-35.
- Buil C., 1994, Meteors, in *The Observer's Guide to Astronomy*. P. Martinez (Ed.), Vol. 2., 1<sup>st</sup> ed. Cambridge University Press, 632-711.
- Ceplecha Z, Borovička J., Elford W.G., Revelle D.O., Hawkes R.L., Porubčan V., Šimek M., 1998, Meteor Phenomena and Bodies. *Space Science Reviews*, 84, 327-471.
- Cervantes de la Cruz K.E., 2009, Estudio petrológico de los condros de las meteoritas

- condríticas mexicanas Cuartaparte, Cosina, y Nuevo Mercurio: origen y evolución de dichas estructuras. Ph. D. Thesis. México, UNAM, 6-7.
- Cordero G., Cervantes de la Cruz K., Gómez E., 2011, The bolide of February 10, 2010: Observations in Hidalgo and Puebla, Mexico. *Geofísica Internacional*, 50-1, 23-30.
- Cordero G., Poveda A., 2011, Curuçá 1930: A probable mini-Tunguska? *Planetary and Space Science*, 59, 10-16.
- Farinella P., Foschini L., Froeschlé Ch., Gonczi R., Jopek T.J., Longo G., Michel P., 2001, Probable asteroidal origin of the Tunguska cosmic body. *Astronomy and Astrophysics*, 377, 1081-1097.
- Flynn G.J., Klöck W., Krompholz R., 1999, Speed of sound, elastic and shear modulus measurements on meteorites: implications for cratering and disruption of asteroids. *LPSC XXX*. 1073.pdf.
- Glass B.P., 1982, Introduction to planetary geology. EEUU, Cambridge, 469 pp.
- Hills J.G., Goda M.P., 1993, The Fragmentation of Small Asteroids in the Atmosphere. *The Astronomical Journal*, 05, 1114-1144.
- Hutchinson R., 2004, Meteorites. A petrologic, chemical and isotopic synthesis. Cambridge, EEUU 524 pp.
- Madiedo J.M., Trigo-Rodríguez J.M., 2008, Multi-station video orbits of minor meteor showers. *Earth Moon Planet*, 102, 133-139.
- Madiedo J.M., Trigo-Rodríguez J.M., Alonso J., Zamorano J., Ocaña F., Docobo J.A., Pujols P., Lacruz J., 2009, The Spanish Meteor Network (SPMN): full coverage of the Iberian Peninsula by mean of high-sensitivity CCD video devices. *European Planetary Science Congress Abstracts*, Vol. 4.
- Madiedo J.M., Trigo-Rodríguez J.M., Ortiz J.L., Morales N., 2010, Robotic systems for meteor observing and Moon impact flashes detection in Spain. *Advances in Astronomy*, 5 pp.
- Madiedo J.M., Trigo-Rodríguez J.M., Konovalova N., Ortiz J.L., Castro-Tirado A.J., Alonso-Azcárate J., Lacruz J., Cabrera-Caño J., 2013, Orbit, emission spectrum, and photometric analysis of two flickering sporadic fireballs. *Astronomy and Astrophysics*, 555, A149, 8 pp.
- Melosh J., 1989, Impact Cratering. A geologic process. Oxford, EEUU, 256 pp.
- Oberst J., Molau S., Heinlein D., Gritzner C., Schindler M., Spurny P., Cepelcha Z., Rendtel J., Betlem H., 1998, The "European Fireball Network": Current status and future prospects. *Meteoritics & Planetary Sciences*, 33, 49-56.
- Passey Q.R., Melosh H.J., 1980, Effects of atmospheric breakup on crater field formation. *Icarus*, 42, 211-233.
- Pater de I., Lissauer J.J., 2001, Planetary sciences. Reino Unido, Cambridge, Capítulo 8, pp. 307-330.
- Popova Olga P., et al., 2013, Chelyabinsk airburst, damage assessment, meteorite recovery, and characterization. *Science*, 342, 29 November, 1069-1073.
- Rubin A.E., Grossman J.N., 2010, Meteorite and meteoroid: New comprehensive definitions. *Meteoritics & Planetary Sciences*, 45, no. 1, 114-122.
- Shumilov O.I., Kasatkina E.A., Tereshchenko E.D., Kulichkov S.N., Vasil'ev A.N., 2003, Detection of Infrasound from the Vitim Bolide on September 24, 2002. *JETP Letters*, 77, no. 2, 115-117.
- Svetsov V., Shuvalov V., 2008, Tunguska Catastrophe of 30 June 1908. In Catastrophic Events Caused by Cosmic Objects., V. Adushkin e I. Nemchinov (eds.) Springer, Países Bajos, pp. 227-266.
- Taylor S.R., 2001, Solar system evolution. A new perspective. Reino Unido, Cambridge. Capítulo 6, pp. 105-161.
- Trigo-Rodríguez J.M., Castro-Tirado A.J., Llorca J., Fabregat J., Martínez V.J., Reglero V., Jelínek M., Kubánek P., Mateo T., de Ugarte Postigo A., 2004, The development of the Spanish fireball network using a new all-sky CCD system. *Earth, Moon, and Planets*, 95, 553-567.
- Trigo-Rodríguez J.M., Llorca J., Docobo J.A., Blanco-Lanza S., Rodríguez-Baquero O.A., 2005, Bóolidos: Cómo estudiarlos y distinguirlos de otros fenómenos luminosos. *Astronomía*. 75, 68-77.



Weisber M.K., McCoy T.J., Krot A.N., 2006, Systematics and evaluation of meteorite classification. In *Meteorites and the Early Solar System II*, D.S. Lauretta and H.Y. McSween Jr. (eds.) University of Arizona Press, Tucson, 19-52.

Yang H-J., Park Ch., Park M-G., 2005, Analysis of historical meteor and meteor shower records: Korea, China and Japan. *Icarus*, 175, 215-225.